



2019 GLOBAL TOURING CAR CHAMPIONSHIP TECHNICAL REGULATIONS (161803/144)

1.	General	2
2.	Technical Inspection	2
3.	Reference Planes and Co-ordinates	3
4.	Vehicle Dimensions	4
5.	Aerodynamic Aids	4
6.	Body and Chassis	4
7.	Fasteners, Hoses and Fittings	5
8.	Weight	5
9.	Cockpit	5
10.	Seating, Belts, Hans	5
11.	Mirrors	5
12.	Windscreen and Sideglass	5
13.	Fire Equipment	6
14.	Electronic Systems	6
15.	Reserved	7
16.	Reserved	7
17.	Reserved	7
18.	Suspension	7
19.	Dampers and Springs	7
20.	Brakes and Ducts	8
21.	Engine	8
22.	Radiators, Coolers	10
23.	Turbo and Wastegate	10
24.	Electrical System	11
25.	Fuel and Fuel System	11
26.	Exhaust	11
27.	Clutch Assembly	11
28.	Propshaft, Driveshafts and Hubs	11
29.	Gearbox	12
30.	Wheels	12
31.	Tyres	12

1. GENERAL

1.1 Eligibility:

Before commissioning the first unit of a new vehicle make, the entrant must receive the agreement in principle from the GTC Commission (GTC) by submitting a specification and sketches/photographs of the proposed vehicle. The entrant must elect a model of a vehicle in the production range on which the the competition vehicle will be based, as well as the engine from the Manufacturer to be used. The details of the model of vehicle and engine will be entered in the Vehicle Technical Passport.

Permission for a make or model to compete in GTC Championship racing may be withheld if it is felt acceptance would not be in the interests of GTC Championship racing.

- 1.2 Documentation will be done by completing in full all the required parameters in the Technical Passport document (TP). It is the duty of each competitor to satisfy the Controllers and the Stewards of the competition that his automobile complies with these regulations in its entirety at all times during the competition.

1.3 Model of vehicle:

Vehicles belonging to a production-series distinguishable by a specific concept and external general lines of the bodywork and by an identical mechanical construction of the engine and the transmission to the wheels. To qualify as a model, the vehicle should have been produced and sold in quantities exceeding 500 in one year in commercial dealer outlets in South Africa. Bodywork variations concerning number of doors, hatchback or boot are permitted and will be considered to be of the same model range.

- 1.4 Safety will always be a top priority with the GTC, and unsafe vehicles, at the sole discretion of the GTC controllers will not be allowed to compete.

- 1.5 All components provided by the Series, an Authorized Manufacturer or Supplier must be used as provided, unless otherwise stated in these rules or in update circulars. All original manufacturer identification markings and/or tags must remain as supplied. For avoidance of doubt, these rules provide for no modification of any component.

- 1.6 Competitors are reminded that the onus rests on the entrant/competitor to ensure that the vehicle always complies in full with the Technical Regulations. Refer MSA GCR's 93 and 176. Ignorance of the law will be no excuse.

GCR 226 I N T E R P R E T A T I O N OF REGULATIONS AND SPECIFICATIONS

In interpreting motorsport regulations and specifications, "what is not specifically permitted is disallowed" is the normal concept in keeping with the French regulations on which all motor sporting regulations are based.

- 1.7 The only binding means of communication shall be in writing.

- 1.8 Definitions: Refer to GTC National Sporting Regulations.

2. TECHNICAL INSPECTION

- 2.1 The responsibility remains with the Entrants to make sure cars conform to all rules throughout an event. All car parts and equipment must complete technical inspection as and when required by the Controllers to be eligible for an event. Officials may inspect all items for conformity of the rules at any time. Completion of technical inspection does not guarantee against disqualification or other penalty if any violation is discovered during any subsequent inspection.

- 2.2 Officials may impound or confiscate a car, part, equipment, item or data associated with a car, driver or entrant, or exchange common parts between cars. In the event of damage or undue wear and tear on an exchange part, the previous owner will be liable for repair costs to bring the part back to serviceable condition.

- 2.3 Certain components will be sealed or marked and registered by the Controllers, and may be

inspected for regulatory conformance at a later date. Should the seal be broken or tampered with in any way without the Controller's instruction and supervision, the competitor will be excluded from the event, and will lose all championship points backdating to the fitting of the seal. In the case of unmarked or differently marked components being found on a car which should have been marked as recorded, the above exclusion penalty will apply.

- 2.4 Attendance at any Technical check or strip and in any parc ferme will be restricted to the following people: the controllers, 1 technician from the required team and 1 nominated Team representative. Should an additional technician be required due to the work load, it may be allowed with the permission of the controllers. No other party may enter these restricted areas, and the allowed parties may only enter in the presence of the controllers, or a duly appointed official. It should be noted that no other parties will be allowed in the post race Parc Ferme and in the strip/technical check area. Transgression of this regulation may lead to exclusion by the Clerk of the Course. Refer GCR 252.
- 2.5 The technical passport as supplied by the GTC must be submitted to technical inspection at the start of any on-track event for the chassis entered.
- 2.6 Officials may examine any car involved in a crash and determine if it is suitable for further participation and all members shall co-operate in the preparation of damage reports, photographs, video taping and impact recording analysis. Any entrant refusing to follow the prescribed inspection procedures may be penalized.
- 2.7 Decorative plating (chrome plating, galvanizing, anodizing, etc) may not be used on any structural metallic parts, unless supplied as such by GTC. All parts which are painted, plated or coated must be stripped before non-destructive testing and inspection.

3 REFERENCE PLANES & COORDINATES

- 3.1 All measurements shall be taken from the reference plane or origin of coordinates. These shall be established by GTC and cannot be modified. References will be measured using the following coordinates:
 - 3.1.1 The X-axis is defined as the longitudinal axis front to rear. The zero X-coordinate is defined as the front face of the engine mounting vertical bulkhead in the chassis. The positive direction is rearwards from zero.
 - 3.1.2 The Y-axis is defined as the lateral axis left to right. The zero Y-coordinate is defined on the longitudinal centreline of the car. The positive direction is to the right from zero.
 - 3.1.3 The Z-axis is defined as the vertical axis from the ground upwards. The zero Z-coordinate is defined as the horizontal plane formed by the lower surfaces of the underfloor rectangular tubing frame. The positive direction is upwards from zero.
- 3.2 For purposes of technical inspection, the chassis reference planes and origin will be marked on each chassis where applicable. These reference points may not be modified in any way. Chassis damage will be addressed on a case to case basis.

3.3 Vehicle Axes:

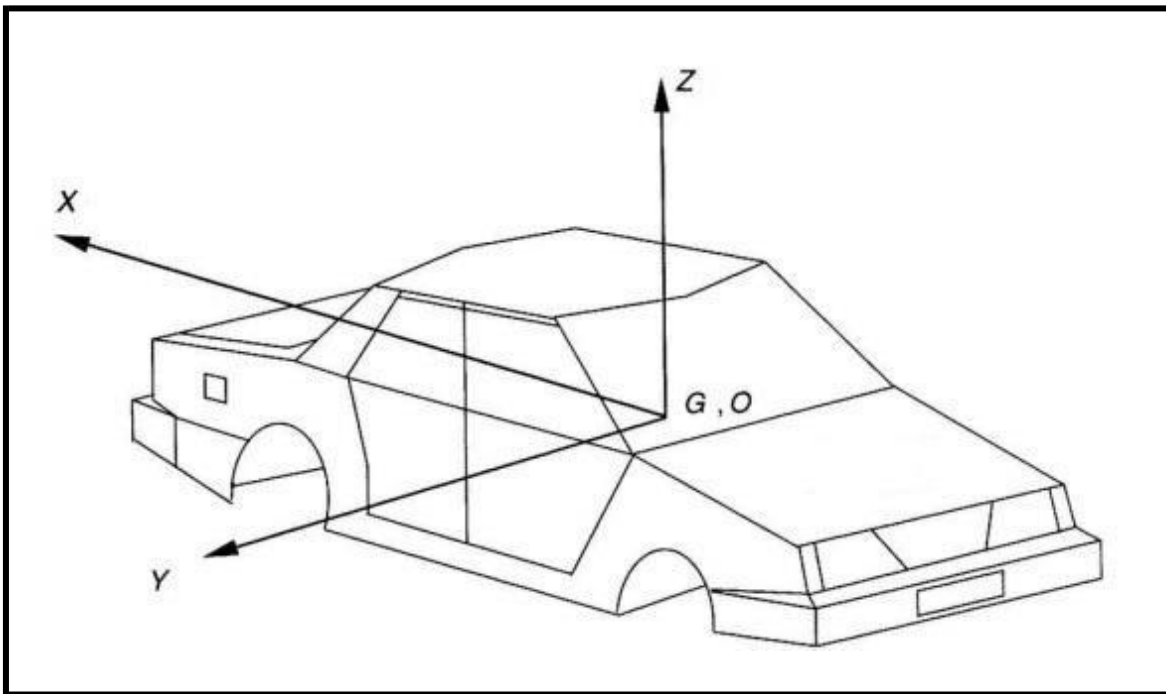

4. VEHICLE DIMENSIONS

- 4.1 All dimensions are measured in mm and must remain within the following tolerances.
- 4.2 Length: 4686mm *nominal (total of wheelbase + rear axle to rear edge of wing + front axle to front of splitter)*
- 4.3 Maximum body width: 1850mm (excluding external rear view mirrors)
- 4.4 Maximum track width - determined by maximum lower control arm(lca) length, std chassis *upper and lower control arm* mounting points, rim offset (no wheel spacers allowed). Ideally the upper half of all the wheels to be covered by the fenders in plan view and in the straight ahead steering position.
- 4.5 Wheelbase: 2726mm \pm 20mm.
- 4.6 Roof height *minimum*: BMW:1120 -5 mm; Audi: 1120 -5 mm; Jetta: 1120mm -5 mm, measured vertically from the top of the driveshaft tunnel to the highest point inside the roof.
- 4.7 *Reserved.*
- 4.8 *Reserved.*

5. AERODYNAMIC AIDS

- 5.1 Both front splitter and rear wing must be run in the location and configuration as specified by GTC, *including the mounting brackets*. All dimensions are measured from the reference planes *as specified in the GTC rear wing and splitter position drawings*.
- 5.2 *The controlling wing position dimensions are:*
 - *the vertical dimension wing height(normalised from chassis) will be 1210 \pm 10 mm.*
 - *the horisontal dimension wing distance from suspension mount, parallel to floor plane, will be 1400 \pm 10mm.*
 - *both dimensions measured to the upper rear end of the wing centre set at highest position ie. lowest drag.*

The stays may be modified to obtain the above dimensions.
- 5.3 Maximum underwing width: 1400mm inside end plates.
- 5.4 *The TC's will approve the position of the wing and splitter, as well as the material of splitter.Their decision is final.*

6. BODY & CHASSIS

- 6.1 All repairs must conform to the Manufacturer's original design criteria including weight.

- 6.2 Structural Repairs - Chassis/Safety Cage structural repairs may only be made by the GTC or a GTC appointed supplier as required by FIA app J art 253. The GTC Controller in his sole discretion will determine whether components are repairable or must be replaced, based on specific safety criteria. Once any component is deemed non-repairable it can no longer be used.
- 6.3 Repairs to other remaining body components not listed above may be performed by Teams or by alternate repair companies provided the original shape and design is maintained. *Fender spats may be blended neatly into the body without changing the shape. The TC's decision is final.*
- 6.4 Remanufacturing of any component not permitted. Completely re-skinning or manufacturing a new part from a mould is not permitted.
- 6.5 Teams are permitted to repair or have components repaired provided they adhere to the following: All structural and sealed/marked mechanical repairs must be declared beforehand to GTC on the series provided declaration form before returning to use, subject to the controller's approval. Declaration is not required for normal service and maintenance. If in doubt, ask.
- 6.6 Doors: inner door panels may be cut out to allow dent repairs. Only the portion of the inner panel marked and approved by the controllers may be removed, no other cut-outs or removals will be allowed. Cut-outs in doors to respect the size and position specified by GTC as recorded in the TP. Anti-intrusion bars in the front doors may not be removed. Door locks, door hinges and their mounting structures may not be modified.
- 6.7 Rear bumpers: the add-in lower panel of the rear bumpers may be removed, and tabs and corners may be trimmed for aesthetic purposes if marked and approved by the controllers.
- 6.8 A weight reduction process may be followed, in which additional cut-outs may be specified by the controllers.
- 6.9 - Cooling air apertures in the bonnet to respect the size and position specified by GTC and recorded in the TP. *The aperture frames may not be higher than 40 mm above bonnet level.*
 - Weight reduction cut-outs in bonnets and boot lids to respect the size and position specified by GTC and recorded in the TP. Sufficient stiffness must remain in the surrounding framework to prevent floppiness in the bonnet and boot. Hinges and their mounting structures may not be modified. Lock pins must be mounted in sturdy structures.
- 6.10 To assist with cabin ventilation the following measures will be allowed:
- 6.10.1 Rear window.
- a) A horizontal slot may be cut in the centre bottom of the rear window. Size not to exceed 400 x 50mm. 80mm above the lower frame of the window. See photos.
- OR
- b) Two reverse transparent Naca ducts at the bottom of the rear window, in line with the wing mounts. Naca duct size not to exceed 200 x 200 x 30 mm. See photos.
- c) Two Naca ducts may be fitted in the sides of the rear window to cool transmission components
- 6.10.2 Rear side windows.
- NACA ducts on each side, with flex hoses internal diameter not exceeding 52 mm, to cool the alternator, gear shift compressor and other equipment. See photos.
- 6.10.3 Front doors.
- a) One flex hose each side through the rear view mirror base in the front door(not through the door panel) , internal diameter not exceeding 52 mm to cool the driver, ECU and other components. See photos.
- OR
- b) The door windows front and rear may be lowered, not exceeding 50mm from fully closed, by fitting sturdy brackets to prevent the windows dropping down or flying out.
- 6.10.4 Dashboard.
- Parallel slots, not exceeding 5 mm in width may be cut in the top of the dashboard above the ECU to provide additional ventilation. See photos.
- 6.10.5 Appearance.
- The installations must be neat and professional and as such approved by the Controllers, whose decision will be final. The modifications must be entered in the TP.
- 6.11 *A cut-out in the floor under the rear seat area may be made directly above the gearbox selector and*

Shiftec to facilitate servicing and repair. The cut-out may not be in or through structural members. The cut-out must have a leakproof and flameproof removable cover to prevent fuel and flames to enter the driver's compartment.

7. FASTENERS, HOSES & FITTINGS

- 7.1 All fasteners must be in place and operational, and must conform to the required specifications.
- 7.2 Tape is not permitted as a single source of attachment for any component. Cable ties may only be used for non-structural applications.
- 7.3 Hoses and fittings of acceptable specification may be individually sourced by teams.
- 7.4 Oil hose diameters may not be downsized from the GTC specification.

8. WEIGHT

- 8.1 The minimum weight of the car at the end of a race includes driver, fuel, all lubricants and coolants. Minimum weight. Refer to GTC National Sporting Regulations.
- 8.2 Minimum weight and front - rear distribution may be determined by GTC and may then not be altered.
- 8.3 Minimum weight means "not less than". All cars will have the same minimum weight.
- 8.4 Cars will be weighed at random and teams may be requested to adjust the car weight at any time.
- 8.5 Any entrant not following the regulations regarding chassis and driver weight will be subject to penalties.

9 COCKPIT

Cockpit regulations are intended for the best interests of the drivers safety, comfort and posture. These must be adhered to in the fullest.

10. SEATING/BELTS/HANS

- 10.1 Seats and seat supports must conform to FIA standard 8862-2009 tech list no 40, and installed as per FIA app J, art 253.16 requirements. All seats and supports will be inspected and approved by GTC before use and are subject to re-inspection at any time.
- 10.2 An FIA approved seat belt with a turnbuckle release mechanism must be used as specified in FIA standard 8853/98 technical list 24, and installed as per FIA app J, art 253.6 requirements. The life of the belts shall not exceed 5 years and must be date stamped by the manufacturer.
- 10.3 Seat belts must be worn in such a manner that they are tight and pass around the pelvis at a point below the anterior superior iliac spines.
- 10.4 Seat belts must not pass over the sides of the seat. They must pass through the seat at the bottom on each side thereby wrapping and holding the pelvis over the greatest possible area.
- 10.5 Frontal Head Restraint (*FHR*) systems *must* conform to FIA standard 8858-2010 as per FIA technical list no 29 *and must be worn as specified.*

11. MIRRORS

- 11.1 The standard OEM door mirrors must be used.
- 11.2 The inside rear view mirror as supplied by GTC is mandatory.

12. WINDSCREEN AND SIDEGLOSS

- 12.1 Standard OEM glass to be used all round with its standard OEM fitment methods. or:
- 12.2 A weight reduction process may be followed, in which acrylic glass(PMMA) may be specified for side and rear windows. The lightweight windows must be shaped to original form, and fitted by standard OEM fitment methods to retain the OEM appearance. The replacement windows must be approved by the TC's and recorded in the TP.
The correct acrylic glass(PMMA) for side and rear windows, 3mm thick minimum, may be obtained from ACES Plastics, Potchefstroom.
Tel nos: 018 294 3077; 082 893 5583; aces@yebo.co.za
The windscreen may not be changed to acrylic, and must remain OEM certified Safety Glass as indicated by the OEM mark on the windscreen.

13. FIRE EQUIPMENT

13.1 Fire equipment provided by the chassis manufacturer must remain in the designated locations. The onboard extinguisher must remain active.

13.2 Fire Extinguishers

All vehicles must be fitted with a minimum of one on-board piped fire extinguisher and one handheld fire extinguisher.

The on-board fire extinguisher as supplied by GTC is mandatory and shall comply with FIA Art 283-2014, article 7 and technical list no 16 as fitted.

The handheld extinguisher is to be fitted in the crew compartment in a place accessible to the driver normally seated with safety harness fastened. The handheld fire extinguishers shall comply with SABS 1910 for the extinguisher cylinder with a minimum capacity of 1,5kg DCP (dry chemical powder) extinguishant. The extinguishant shall be MAP (mono-ammonia-phosphate), containing a minimum of 70% MAP in the DCP (Note the 70% is higher than the industry standard 40% and is available). The DCP shall comply with SANS 1522.

All extinguishers must be secured by a minimum of 2 screw-locked metallic straps and the securing system must be able to withstand a deceleration of 25 g in the three normal directions. Furthermore, only quick-release metal fastenings with metal straps will be accepted.

The following information must be visible on each handheld extinguisher:

- capacity
- type of extinguishant
- weight or volume of the extinguishant
- date the extinguisher must be checked, which must be no more than one year after either the date of filling or the date of the last check, or corresponding expiry date.
- each extinguisher must be equipped with a pressure gauge to check the pressure of the

contents.

Note:

Fire extinguishers in vehicles should ideally be checked every six months, as the extinguishant can compact with road vibration. Turn upside down and shake to loosen the powder.

14. ELECTRONIC SYSTEMS

14.1 Life Racing is the only approved electronics supplier unless otherwise specified. This includes but is not limited to engine ECU, chassis and data looms, data acquisition, sensors, steering wheel and display. All cars must use data recorders as supplied by GTC. Components must be used as supplied without modification.

14.2 The approved sensor list for use during race events is as follows:

- Damper pots (4)
- Steering pot (1)
- Wheel speed sensors (4)
- Brake pressure sensors (2)
- Clutch pressure sensor (1)
- Coolant pressure sensor (1)
- Gear position sensor (1)
- Gearbox temperature sensor (1)
- Gearbox pressure sensor (1)
- Throttle position sensor (1)
- Exhaust gas temperature sensor (1)

14.3 Wireless data download will not be allowed during qualifying and races, and equipment must be disconnected or removed. *Equipment must be mounted in the driver's compartment where it is clearly visible for the TC's and officials to see if it is disconnected.*

14.4 Steering wheel - The steering wheel must be used as supplied by GTC. Modifications are not permitted. This includes all buttons, switches, paddles and grips. Position of controls may be changed to suit driver preferences. *The TC's decision is final.*

14.5 Exhaust gas temperature sensor to be sourced by competitors.

- EGT: Thermon part no. USTA1SX-KY3868A (U) D3 obtainable from
Toni.Zeeman@thermon.com 021 762 8995

- EGT weld-on fitting: Swagelok part no. SS-3M0-1-2W obtainable from Nangamso.Mnguni@Johannesburg>Swagelok.com 011 609 7925
- EGT to be fitted in exhaust manifold between 20 to 40 mm from Turb V-band flange.

- 15. Reserved
- 16. Reserved
- 17. Reserved

18. SUSPENSION AND STEERING

- 18.1 All suspension components as provided by GTC must be used without modification. Adjustment using the adjustable rod-ends is free, provided there is always more than 1½ diameter of thread used, not counting the lock-nut. For 2019 season, all cars may be upgraded to fine thread rod-ends as supplied by GTC. The following "Motor Sport" bearings may be used as an option:

Aurora Bearings:

- i) Rodend M12x1,25 RH male MMF-M12T
- ii) Rodend M12x1,25 LH male MBF-M12T
- iii) Rodend M12x1,75 RH male MM-M12T
- iv) Spherical Bearing Φ12 GE 12 MTE
- v) Spherical Bearing Φ15 GEH 15 MTE

FK Bearings:

- i) Spherical bearing φ 5/8" WSSX10T
- ii) Rodend ½"-20 tpi JMX -8T
- iii) Rodend 5/8"-18 tpi JMX-10T
- iv) Rodend 5/8"-18 tpi, ½"pin RSMX-8T

NMB Bearings:

- i) Rodend 5/8"-18 tpi, ½"pin ARHT8ER

The minimum necessary suspension component modifications to fit the rod-ends will be allowed, provided there are no geometry changes. Cross bars already fitted to some lower front wishbones will be allowed until they have to be replaced, but no new cross bars because of the welding risk.

- 18.2 Toe, camber and castor may be adjusted, provided they are within the chassis manufacturer's suspension specifications.
- 18.3 Shim type toe adjusters for the rear toe-rods will be supplied by GTC as an option.
- 18.4 Anti-roll bars must be used without modification as supplied by GTC. They may be adjusted or disconnected, but no parts may be removed.
- 18.5 Rockers must be run as supplied by GTC without modification.
- 18.6 The steering rack must be used as supplied and specified by GTC.
- 18.7 Uprights must be used as supplied and specified by GTC. *Front and rear, left and right upright components and assemblies are interchangeable and may be used as required.* Wheel bearings as provided by GTC. Hybrid and/or ceramic bearings are not approved for use.

19. DAMPERS AND SPRINGS

- 19.1 The only approved damper which may be used are the Ohlin Dampers as specified and supplied by GTC. The dampers must be run without modification as supplied by GTC. The dampers will be marked and sealed, and will be serviced by GTC only. The damper specification for all GTC cars is: GTC Specification Card OHLINS TTX36IL version 1, dated 01/03/2016, and obtainable from GTC.
- 19.2 Damper configuration is specified and may not be changed. The dampers have external adjusters on the damper body, which may be set by the teams.
- 19.3 Only linear rate steel springs are permitted, and only the rates as specified by GTC.
- 19.4 Front Springs on Front and Rear Springs on Rear.

Front springs:	01093-64/160	Rear springs:	21040-39/110
	01093-69/170		21040-44/120
	01093-74/180		21040-49/130

20. BRAKES AND DUCTS

- 20.1 Brakes must be used in its entirety as supplied by GTC.
- 20.2 Brake calipers must be used as supplied. Any devices designed to push or pull back pistons (other than knock back springs) are not permitted. Caliper seals must be used as supplied by GTC without modification.
- 20.3 The brake pads as supplied by GTC must be used without modification.
- 20.4 Master cylinder bore sizes are a team sourced option.
- 20.5 Brake fluid is a team sourced option.
- 20.6 The brake ducts must be used as supplied without modification. *The brake duct hose diameter may not exceed 76 mm.* Tape is the only approved method for regulating airflow into the brake ducts. Brake ducts are mandatory. *No additional cutouts may be made in the front bumper/grille assembly and front fenders to allow for additional brake cooling air.*

21. ENGINE

- 21.1 The engine as supplied by the manufacturer will be in Group N specification with dry sump system and water pump modifications and any other specifications stipulated by GTC. The engine must be used as supplied, without any additional modifications or additions whatsoever, unless specified in a circular. Any variation from specifications regarding installation, oil pump, oil sump, oil tank, oil and filters, fuel, turbocharger, exhaust or waste gate will result in race exclusion and loss of championship points. Teams are to follow operating instructions as provided by the controllers, who will seal all race engines. Broken seals without a TC's approval will result in exclusion and loss of championship points. Should a team want to open an engine for repair, the TC should be contacted, and arrangements may have to be made for a TC to be present when the seals are removed. The TC may then check engine specifications if so required. The TC will reseal the engine after repair. The onus is on the Team to ensure the engine is to specification, sealed and recorded. Refer Art's 2.1 and 2.3. The correct engine number must always be recorded in the TP.
- 21.2 The engine's drive belts must always be connected and operational.
- 21.3 The engine installation position is as specified in the GTC technical specifications, and may not be modified. Any variation from specifications regarding installation position will result in race exclusion and loss of championship points.
- 21.4 Coolant water - anti-freeze containing glycol will not be allowed due to the additional fire risk and motor cycle regulations when racing on the same day.
- 21.5 The ECU is provided, controlled and administered by GTC. Software changes will take place under the direction of GTC only. Once set, the ECU will be locked selectively by the TC or appointee.
- 21.6 Inlet air filter - The air filter as supplied by GTC must be used without modification.
- 21.7 Oil catch tank - the lubrication breather system must be equipped in such a way that *the overflow oil flows into an* oil catch tank. This must have a capacity of 2 litres for cars with a cubic capacity equal to or below 2000 cc, and 3 litres for cars with a cubic capacity of over 2000 cc. This container must be made either out of plastic or must include a transparent window.
- 21.8 Valve lift - engines with variable valve lift shall be locked in the maximum lift position. The hydraulic valve lifters must remain standard OEM and may not be modified.
- 21.9 The EWP 150 alloy water pump, part no 8060 may be used as an alternative to the BMW 150 liter/min electrical pump.
- 21.10 The BMW N20 engine may only use the steel fabricated exhaust manifold made to the VM Innovation jig. The tube size on the cylinder head side is ID 37,5 ± 1mm. The flange on the turbo side mates to the Garrett AR 61 V-band turbo flange.
- 21.11 The following connecting rods and pistons may be used in addition to the standard OEM components as a reliability option. The standard OEM bore and stroke must be retained.
 - 21.11.1 BMW N20 standard bore:
 - Piston part no - Carillo SC 7700
 - Connecting rod part no - Carillo BM_BN20_OHS_5683B6S
 - The cylinder bores may be re-sleeved to standard OEM bore size.*
 - 21.11.2 VW EA888 CJX standard bore:
 - Piston part no - Carillo SC 7633
 - Connecting rod part no - Carillo VW_BTSI_3HS_5670B66

Main bearing cap stud part no – ARP 204-5408

The cylinder bores may be re-sleeved to standard OEM bore size.

21.12 Flywheel and crankshaft damper.

21.12.1 The BMW N20 engine may use a steel flywheel fitted to the crankshaft with external diameter not exceeding 210 mm, and width not exceeding 20 mm. Mass not exceeding 4,6 kg. Refer drawing VM Innovations GTC-FLW-01-01. The BMW N20 OEM balance shafts are optional.

21.12.2 The VW EA888 CJX engine may use a steel flywheel fitted to the crankshaft with external diameter not exceeding 199,5 mm, and width not exceeding 20mm. Mass not exceeding 5,85 kg with integral adapter, and mass not exceeding 4,2 kg without adapter. Refer TMR drawings dated 31/03/2017. The VW EA888 OEM balance shafts are optional.

21.12.3 The VW EA888 engine may use a hydraulic crankshaft vibration damper fitted to the nose of the crankshaft. "Fluidamper" part no 551231.

21.13 Dry sump oil pump system.

21.13.1 Pump and crankshaft drive pulleys:

- fit the pump pulley retainer as per GTC drawing GTC-OP-01 (+ GTC-OP-02 optional) to prevent the pulley moving forwards and backwards on the shaft, preventing loss of the drive belt.

- both the drive pulleys have to be reworked to fit the drive belts. The outer diameter (narrow "teeth") of the pulleys have to be decreased slightly to allow the belt to carry the load on the rounded portion of the teeth without the belt touching the narrow ends of the teeth. The best way to do this is to clamp the pulley in a lathe chuck and run fine emery tape over the outside diameter. Take care not to make a cone shape. It only requires 0,1 to 0,2 mm material removal, as well as deburring or slight chamfering of the narrow teeth outer corners. Put a belt around the pulley, pull tight by hand, hold against a light. A sliver of light should be visible between belt and narrow ends of teeth, whilst no light should be visible through the rounded parts. Engineer's blue can also be used to check.

Always inspect the inside of the belts for undue wear on the narrow flat portion between

the rounded teeth, as well as in the corners between the narrow flat portion and the rounded teeth.

Wear on the two sides of the belt indicate mis-alignment between the two pulleys. Also inspect for stone damage. Small stones kicked up and getting caught between belt and teeth can punch through the belt backing and cause failure. Belts should always be inspected after a trip into the kitty litter.

21.13.2 Pump stay:

Fit the pump bracket stay from the back of the pump housing to the engine block as per GTC drawing. This component is required to prevent the pump moving when a belt load is applied. The pump movement may lead to belt mis-alignment and loss of the drive belt.

21.14 The Volkswagen EA888 CJX engine may optionally disconnect the long-short inlet tract butterfly system in the inlet manifold, and accordingly remove the splitter blades in the inlet ports.

21.15 Engine static volumetric compression ratio:

This specification is intended to keep engines racing at minimum cost, and not as a performance enhancer. Please treat as such.

21.15.1 Volkswagen EA888 CJX engine:

1) Compression ratio not to exceed 9,6:1 (standard CR is 9,3:1)

2) Reserved

3) Cylinder block height measured from block deck to sump face: 278,0 mm standard. Deck skim 0,15 mm allowed to 277,85 mm minimum.

4) Cylinder head gasket thickness. Standard compressed is 0,8 mm. Non-standard gaskets with thickness up to 1,1 mm maximum compressed will be allowed.

5) Piston protrusion above block deck will be allowed, but squish must be a minimum of 0,6mm without machining the piston crown or the combustion chamber.

6) Any of the above specified combinations of head skim, block skim and gasket thickness will be allowed so as to remain within the 9,6:1 CR maximum and respect the minimum squish. The 9,6:1 CR is the primary parameter in this regulation.

7) The combustion chamber and ports shall remain standard OEM, but a combustion chamber volume of not less than 43,5cc will be allowed.

21.15.2 BMW N20 engine:

1) Compression ratio not to exceed 10,1:1 (standard CR is 10,05:1)

2) Reserved.

3) Cylinder block height measured from block deck to sump face: 221,60 mm standard. Deck skim 0,50 mm allowed to 221,10 mm minimum.

4) Cylinder head gasket thickness. Standard compressed is 1,0 mm with Carillo pistons (std N20 engine is 0,7 mm). Non-standard gaskets with thickness up to 1,3 mm maximum compressed will be allowed.

5) Piston protrusion above block deck will be allowed, but squish must be a minimum of 0,8 mm without machining the piston crown or the combustion chamber.

6) Any combination of head skim, block skim and gasket thickness will be allowed so as to remain within the 10,1:1 CR maximum and the minimum squish. The 10,1:1 CR is the primary parameter in this regulation.

7) The combustion chamber and ports may be modified to the specified standard by van der Linde Systems. Valve sizes must remain standard. A combustion chamber volume of not less than 40,0 cc will be allowed.

21.16 Cylinder head studs:

To improve engine reliability the following specialised studs will be allowed to replace the cylinder head bolts as an option:

- BMW N20 engine: designed and supplied by VM Innovations /vic@vminnovate.co.za
- VW EA888 CJX engine: ARP 204-4302

22. RADIATORS/COOLERS

22.1 Only the approved radiators and intercoolers specified by GTC may be used without modification. Water, oil and intercooler pipes must remain as supplied except for fitment related issues.

22.2 The fitting of a micro water spraying system in front of the radiators will be allowed. A 10 liter (max) water tank may be fitted with an electric pump controlled by a driver actuated on-off switch, or temperature and/or boost controlled switch actuated by the ECU. The sprayers may not be positioned to spray water into the engine combustion air inlet in any way. The TC's will approve the position of the sprayers, and their decision is final.

Only clean water, suitable for human consumption, may be used. NO additives will be allowed.

No weight compensation will be allowed. The minimum race weight remains as per the Sporting Regulations

22.3 The following charge air intercooler core must be used:

GTC supplied core - CSF 8047 12 fin rows, size 560 x 218 x 90. Tube sizes not to exceed 63,5 and 50,4 mm OD respectively. The tank design is free, but must be approved by the TC's. The intercooler must be fitted on top of the water radiator as approved by the TC's.

An IC air exit may be made in the bonnet as per clause 6.9

Ducting of air to the water radiator and charge air cooler is free, provided no additional cutouts are made in the chassis, body, grille or bumper.

23. TURBO & WASTEGATE

Turbochargers are provided by Turbo Direct (Chris Kambouris / 011 3925195 / chris@turbodirect.co.za / leigh@turbodirect.co.za) . These are the only the turbochargers approved by GTC and must be used without modification.

Complete Turbocharger:

- Garrett GTX3071R Gen II AR61 V-band in & out.
- Assy Part no: 856801-5018S.
- *Compressor* part number: 851154-5002S. *0,60 AR*
- Turbine part number: 740902-0036. *0,61 AR*

Wastegate:

- Xcell Performance 50mm water - cooled wastegate.
- Precision Turbo and Engine PW46 External Wastegate. Part no PBO 085-2000
- *Precision Turbo PW 46 water-cooled waste gate. Part no PBO 085-2200*
- *Tial MV-R water-cooled waste gate.*
- *Turbosmart WG45HP Hypergate 45 mm 14 psi waste gate. Part no TS-0506-1040/1*

Blow-off valve:

- Excell Performance 38 mm dump valve.

24. ELECTRICAL SYSTEM

- 24.1 The only approved electrical system fitted to the car is the system supplied by GTC, to the GTC electrical specification. No modifications, additions or deletions are allowed.
- 24.2 The approved 90 A and 120 A alternators are supplied by GTC, or may be team sourced with written approval *from the TC's*.
- 24.3 The PDM may be doubled to allow 20 channels if required and supplied by GTC only.
- 24.4 Battery - The only battery approved for use is the one provided by GTC.
- 24.5 The external emergency shutoff switch must be clearly marked using the decal supplied by the GTC.

25. FUEL & FUEL SYSTEM

- 25.1 The only approved fuel is 98 octane petrol conforming to MSA GCR 240 as supplied by the GTC fuel sponsor. See GTC Sporting Regulations and Specifications para 9. Fuel must be stored and used at ambient temperature and no additives whatsoever may be used. Fuel may be sampled and subjected to testing at any time.
- 25.2 The fuel system must remain as supplied by GTC. This includes the fuel pump and filter specifications.
- 25.3 Plumbing of the fuel lines are free, provided the internal hose diameters are not changed. When flexible, these lines must have threaded, crimped or self-sealing connectors and an outer braid cover, resistant to abrasion and flame (does not sustain combustion). *The hoses must be clamped to the car at regular intervals to prevent abrasion and pinching.*
- 25.4 Lines containing fuel or hydraulic fluid may pass through the cockpit, but without any connectors inside except on the front and rear bulkheads according to FIA Drawings 253-59 and 253-60, and on the braking circuit and the clutch fluid circuit.
- 25.5 The fuel tank, fuel pumps and fuel filters must be separated from the driver by a liquid-proof and fireproof protection.
- 25.6 There must be an orifice to evacuate any fuel which may have spread into the tank compartment.
- 25.7 All the fuel pumps must only operate when the engine is running, and during the starting process.
- 25.8 The position and the dimension of the fuel filler hole as well as that of the cap may be changed as long as the new installation does not protrude beyond the bodywork and guarantees that no fuel leaks into one of the interior compartments of the car.
- 25.9 If the filler hole is situated inside the car, it must be separated from the cockpit by a liquid-proof and fireproof protection.
- 25.10 The ventilation line of the fuel cell as far as the valves described below must have the same specifications as those of the fuel lines, and must be fitted with a system complying with the following conditions:
 - Gravity activated roll-over valve
 - Float chamber ventilation valve
 - Blow-off valve with a maximum overpressure of 200 mbar, working when the float chamber ventilation valve is closed.
- 25.11 If the internal diameter of the fuel tank breather venting tube is greater than 20 mm, a non-return valve homologated by the FIA and as defined in Article 253-14.5 must be fitted.

26. EXHAUST

The exhaust system *basic lay-out must remain as specified* by GTC. To limit heat damage to components, removable heat insulating wrapping of the inlet air and exhaust ducting, including turbocharger will be allowed. Removable heat shields may be added, subject to the approval of the TC's. Ceramic and other coatings will not be allowed. *All subject to the approval of the TC's.*

27. CLUTCH ASSEMBLY

- 27.1 GTC is the only approved clutch supplier.
- 27.2 The clutch master cylinder bore size is a team choice.

28. PROPSHAFT, DRIVESHAFTS & HUBS

- Only parts provided by GTC are permitted. These must be used as supplied without modification.
- 28.1 Propshaft: The propshafts are under development and a work-in-progress for 2019. The current

fabricated and machined propshafts must be maintained and run as effective as possible until further notice.

29. GEARBOX

- 29.1 Use of the Albins gearbox system as supplied by GTC is mandatory.
- 29.2 The gearbox position must remain as per GTC specification and may not be changed. Any variation from specifications regarding installation position will result in race exclusion and loss of championship points.
- 29.3 Coatings of any kind or Super Finishing is not permitted.
- 29.4 Shifttec is the only approved shift mechanism. This must be used without modification and as supplied by GTC unless otherwise approved by the controllers.
- 29.5 All six (6) speeds must remain in the gearbox during on track activity. Reverse must be functional at all times during the race, and the driver must be able to engage it from the cockpit.
- 29.6 Differential must be run as supplied, and to the GTC specification.
- 29.7 Accessories - Filters, screens and magnetic plugs are allowed provided they serve no other purposes.
- 29.8 The bell housing must be used as designed and supplied without modification.
- 29.9 The starter motor as supplied by GTC is the only approved system for use.
- 29.10 The alternator drive belt must always be connected and the alternator operational.
- 29.11 *Air to oil coolers for the gearbox may be fitted at the rear of the car. No additional external body cut-outs for cooling air. All subject to the approval of the TC's.*
- 29.12 The only gearbox internals approved for use are as follows:

RATIOS	
INPUT	1.000
DROP GEAR	1.091 or 1.13
1ST	2.357
2ND	1.824
3RD	1.474
4TH	1.238
5TH	1.043
6TH	1.000
Final Drive	3.273
Diff Ramps	-

*Drop gear ratio long - 23:23 teeth. 1:091
- gear part numbers: Albins P13810 and P13811
Drop gear ratio short - 23:26 teeth. 1,1304:1
- gear part numbers: AlbinsP13808 and P13809*

30. WHEELS

GTC will supply the only approved wheels permitted to be used during all race weekends, series open tests and promotor test days. Wheels may not be modified, and may only be repaired with the approval of GTC.

31. TYRES

- 31.1 Only the following tyre compound and construction can be used by GTC:
- 31.1.1 - Dunlop 280/680R18 S slick soft GTC.
- 31.1.2 - Dunlop 280/680R18 D92 rain tyre.
- 31.1.3 - Tyre order process:
- All teams/competitors will send a written order on the form below to GTC - shelley@gtcafrica.co.za / 0824689200
 - GTC will approve the order and send approved order to ATS

- iii) ATS can only invoice and supply tyres to teams/competitors when it has received this written confirmation from GTC.
 - iv) If approval is not forthcoming from GTC no tyres may be supplied to the team/competitor placing the order - this is not negotiable.
 - v) ATS must ensure payment is received directly from the team/competitor - not GTC.
 - vi) A week before the end of every month or every race (whichever comes first) ATS must send to GTC all the tyre numbers allocated to each competitor (testing and races) in order for GTC to ensure that both parties (ATS and GTC) have the same orders versus deliveries.
 - vii) This document will then be circulated to the relevant teams/competitors so that total transparency exists.
- 31.2 A total number of tyres per entry will be allocated and controlled for the season. Teams that do not enter or start a race shall have pro rata less tyres. 4 per event.
- 31.2.1 60 x Dunlop slick tyres for the whole season. Four new per race meeting, rest from previously used and marked. 8 new for first race.
- x36 for nine race meetings.
 - +4 extra allowed for FOM race at Kyalami.
 - + 4 for race 1.
 - + 16 for practice & testing for the year. Total: 60 tyres for the season
- 31.2.2 The four new tyres must be used for qualifying and the same tyres must be used for the two races.
- 31.2.3 Damaged tyre replacements *for races* to be taken from previously used and marked *in the same season* for the specific car. *The replacement tyre must be of equivalent wear to the damaged tyre. The tyre numbers must be recorded by ATS and approved by the TC's.*
- 31.2.4 1 x set of new rain tyres.
- 31.3 Tyres will be marked and recorded per car. No tyre swapping between cars or teams.
- 31.4 It is the responsibility of the competitor / entrant to ensure that the tyre markings remain on the tyres, as the use of unmarked tyres at any time may result in the exclusion of the offending competitor from the session or race concerned.
- 31.5 Only Nitrogen or air may be used to inflate tyres.
- 31.6 Pressure controlling devices / valves must not be used.
- 31.7 Teams must not chemically treat or alter the tyres.
- 31.8 Tyre blankets, tyre warming devices and heaters are not allowed.
- 31.9 The Endurance race tyre allocation shall be part of Endurance Race rules as per MSA circular.