



Driver Conduct and Penalties (161754)

Contents

- 1 General
- 2 Definitions
- 3 Driver Conduct
- 4 Penalties

1. General

1.1 These Regulations are to serve as guidance in regards to driver conduct and associated penalties.

2. Definitions

2.1 Racing incident – neither drivers were impeded nor gained any advantage from an on track incident.

2.2 Collision – Incident resulting from contact impeding one or more drivers.

2.3 DQ – Disqualification

2.4 Excl. - Exclusion

3. Driver Conduct

3.1 Observance of signals and officials instructions

3.1.1 Observance of signals the instructions detailed in MSA General Competition Rules appendix “H” are deemed to be part of this Code of Driving Conduct. All Drivers must abide by them.

3.2 Overtaking during a race

3.2.1 A kart alone on the track may use the full width of the said track. However, as soon as it is caught by a kart which is about to lap it the Driver must allow the faster Driver past at the first possible opportunity. If the Driver who has been caught does not seem to notice that another Driver wants to overtake him, flag Marshals will display waved blue flags to indicate that the faster Driver wants to overtake. Any Driver who appears to ignore the blue flags will be reported to the Stewards of the meeting.

3.2.2 Overtaking, according to the circumstances, may be carried out either on the right or the left. However, manoeuvres liable to hinder other Drivers such as more than one change of direction to defend a position, deliberate crowding of karts beyond the edge of the track or any other dangerous change of direction, are strictly prohibited. Any Driver who appears guilty of any of the above offences will be reported to the Stewards of the meeting.



- 3.2.3** Drivers must use the track at all times. For the avoidance of doubt: - the lines defining the track edges are considered to be part of the track but kerbs are not. - A Driver will be judged to have left the track if no part of the kart remains in contact with the track. Should a kart leave the track for any reason, and without prejudice to 3.2.4 below, the Driver may re-join. However, this may only be done when it is safe to do so and without gaining any advantage.
- 3.2.4** Repetition of serious mistakes or the appearance of a lack of control over the kart (such as leaving the track) will be reported to the Stewards of the meeting and may entail the disqualification of any Drivers concerned.
- 3.2.5** Contacts / collisions: penalties may be imposed on a Driver who causes a collision with another Competitor.

3.3 Karts stopping on circuit

- 3.3.1** The Driver of any kart leaving the track because of being unable to maintain racing speed and should signal the intention to do so in good time and is responsible for ensuring that the manoeuvre is carried out safely and as near as possible to a point of exit.
- 3.3.2** Should a kart stop outside the pit lane or outside the Repair Area, it must be moved as soon as possible when it is safe to do so in order for its presence to not constitute a danger or hinder other Drivers.
- 3.3.3** Replenishment of fluids any kind is prohibited on pre-race grid or on track.
- 3.3.4** Apart from the Driver and duly appointed officials, nobody is allowed to touch a stopped kart except when in the pit lane or in the Repair Area.
- 3.3.5** Except during a race suspension, any kart abandoned on the circuit by its Driver, even temporarily, shall be considered as withdrawn from the race.

3.4 Entrance to the pit lane (to the Repairs Area or to the Servicing Parks)

- 3.4.1** The so-called «pre-race grid» is a part of the pits area. The section of track leading to the pit lane shall be referred to as the «pit entry».
- 3.4.2** During the practice sessions and the race, access to the pits lane, to the Repairs Area or to the Servicing Parks is allowed only through the pit entry.

3.5 Race completion

- 3.5.1** Race will be deemed complete once competitor received the chequered flag and crossed the finish line
- 3.5.2** Competitors need to maintain a steady speed till track exit has been reached.



4. Penalties

***TABLE 1

Infringement	1 st offence	2 nd offence	3 rd offence +
Starting procedure infringements - event duration			
Tram lines	3 sec	3 sec	3 sec
Jump Start	3 sec	3 sec	3 sec
Driver conduct – event duration			
Section 3.1	Warning	3 sec	10 sec
Section 3.2.2	3 sec	5 sec	Excl.
Section 3.2.5	5 sec	10 sec	DQ
Section 3.3.1	Warning	10 sec	Excl.
Section 3.3.3	*Liable to a Fine	Excl.	DQ
Section 3.3.4	Warning	Excl.	DQ
Section 3.4.2	Warning	Fine = R1000	Fine = R2000
Section 3.5.2	Warning	Fine = R1000	Fine = R2000
Section 4.12 and 4.13	DQ	DQ	DQ
Technical	DQ	DQ	DQ
Driver conduct – season duration			
**Nose cone – Partial dislodgement	Warning	3 sec	3 sec
**Nose cone – Complete dislodgement		5 sec	5 sec
<p>*Fine amount will be equal to quotes submitted by the hosting club for the repairs. Failure to pay will result in a DQ for the heat prior too to within the transgression occurred.</p> <p>** Refer to appendix A</p> <p>*** Depending on the severity of the incident and/or if deemed deliberate the stewards have the discretion to opt for immediate disqualification for the infringement. Multiple infringements in the same race can also be compounded.</p>			

- 4.1 Any breach of the GCR's, these regulations, or the supplementary regulations for any competition whether or not any penalty is specified therein, may be subject to the further penalties laid down in the general competition rules of MSA and the imposition of such conditions as MSA may deem appropriate.
- 4.2 Any contravention of the karting technical regulations and specifications will result in automatic exclusion from the relevant race or the entire event as per decisions of the Stewards or MSA.
- 4.3 With reference to Appendix H of the MSA General Competition Rules, a driver who receives a black flag shall be regarded as a non-finisher and shall score a "DQ" for the race concerned.
- 4.4 Underweight
- 4.4.1 Competitors and/ or karts found to be underweight will receive zero (0) points as a non-finisher. The lap times set in the heat will also be disregarded for grid positioning for the next race.
- 4.5 In the event that a competitor is shown the mechanical flag, the competitor must pit within (2) laps. Failure to do so will result in the exclusion of the competitor from the race concerned.



- 4.6 Under no circumstances may a kart be driven or pushed in any direction, except in the direction of the course, either during unofficial or official practice sessions or during a race meeting. Failure to observe this rule shall mean exclusion from the entire race meeting.
- 4.7 From the commencement of the official qualifying practice only authorized officials are allowed on the track. The penalty for receiving outside assistance, whether the assistance is solicited or not, is automatic exclusion from that particular race or qualifying. Restarting of a kart with the assistance of an official will be regarded as outside assistance.
- 4.8 Exchanging of tyres between competitors is forbidden and the penalty will be exclusion all competitors involved.
- 4.9 Any proceeding, derogatory action, or interference with or against a race official by entrants, drivers, or their assistants shall be considered a breach of GCR 172 (iv) and shall make the entrant liable to a penalty and/or a fine. (Refer to GCR 121 for the definition of responsibility).
- 4.10 Penalties will be applied to the finishing order of a race, qualifying session or qualifying race in which the offence occurred.
- 4.11 A competitor disqualified for technical infringements, will start the next race of the event from the back of the grid. That being the case, the competitor may start in the grid position based on the lap time posted if a protest have been lodged, however should the competitor loose his/her protest and or subsequent appeal, he/she will be excluded from both races. Should the competitor, having taken up his/her rights of protest/appeal, nevertheless choose to start from the back of the grid, the result of that race will be valid and will not be affected, irrespective of the outcome of the protest.
- 4.12 Any competitor or any other party found to be tampering with or resetting the positioning his/her nosecone, as from when the kart fell under starter's orders till after crossing the scale, the competitor will be disqualified. This decision is final and non-protetable.
- 4.13 Competitor found with any sort of modification or device that could prevent the front fairing to "push in" will be disqualified.



Appendix A

DESSINS TECHNIQUES
TECHNICAL DRAWINGS

DESSIN TECHNIQUE N° 2d

Installation correcte du «Carénage Avant»

Position correcte / Correct position

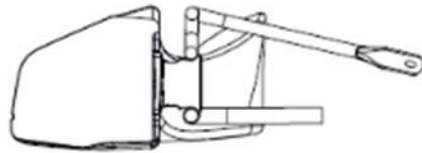

TECHNICAL DRAWING No. 2d

Correct installation of the "Front Fairing"

Position acceptable / Acceptable position

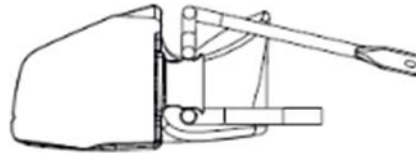

Position non acceptable si une quelconque partie des tubes du pare-chocs avant se trouve dans les zones marquées (A).

Not acceptable position if any part of the tubes of the front bumper are in the marked areas (A).

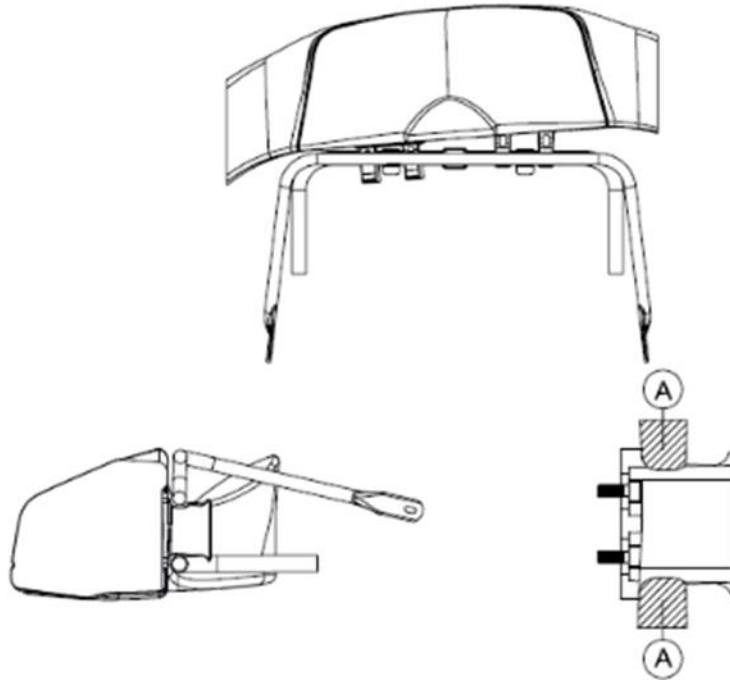

Partial dislodgement – One side of the bumper is in the incorrect position

Complete dislodgement – Both sides of the bumper is in the incorrect position.