



2020 NATIONAL KARTING CHAMPIONSHIP REGULATIONS AND SPECIFICATIONS (162083)

VERSION 5 – 26 June 2020

<i>Modified SSR / ART</i>	<i>Date applicable</i>	<i>Date of Publication</i>	<i>Clarifications</i>
ART 15	Immediate effect	14.02.2020	Entrant requirement – Wording added
ART 15 iii)	Immediate effect	14.02.2020	KZ2 shifter class - Wording deleted
ART 4 i, j, k, l	Immediate effect	07.04.2020	Wording added
ART 9	Immediate effect	07.04.2020	Wording amended
ART 11 a	Immediate effect	18.06.2020	Wording amended
ART 11 c	Immediate effect	07.04.2020	Wording amended
ART 11 c iii	Immediate effect	18.06.2020	Wording amended
ART 18 xx	Immediate effect	07.04.2020	Wording deleted
ART 18 xxiii	Immediate effect	07.04.2020	Wording amended
ART 21	Immediate effect	18.06.2020	Wording added
ART 26	Immediate effect	07.04.2020	Importer details updated

ARTICLE		PAGE
1	Administration	2
2	Classification of Competitions	2
3	Organising Permits	2
4	Circuits - Requirements	2- 4
5	Circuit Plan	4
6	Obligatory circuit installations	4
7	The following equipment is mandatory	4-5
8	MSA permit issue	5
9	Officials	5-6
10	Rights & Duties of Organiser	6-7
11	Penalties	7-13
12	Scrutiny	13
13	Supplementary Regulations	13
14	Awards	13
15	Competitors – General	13-18
16	Vehicles – general	18
17	Practicing	19

18	Racing – general regulations	19-23
19	Points Scoring	23
20	National Championship – general format	23
21	Observation Form	23
22	Protests	23
23	Appeals	24
24	Karting specifications – general	24-27
25	Homologation	27-28
26	Chassis & Engines	28-31
27	Accredited Kart Importers	31-33

1. ADMINISTRATION

- i) Karting is administered under the provisions of the General Competition Rules of Motorsport SA (GCR's), these Standing Supplementary Regulations (SSR's), **the Standing Supplementary series specific Regulations and** other regulations and instructions which may from time to time be issued by Motorsport SA (hereinafter referred to as MSA) and the Supplementary Regulations published for each particular kart competition.
- ii) Where there is a contradiction between the GCR's and these SSR's the latter shall take precedence. Where there is a contradiction between these SSR's and the pertinent national series SSR's, the latter shall take precedence
- iii) NB: The SSR's applicable to circuit racing do not apply to karting, except in cases where kart racing is held in conjunction with car and/or motorcycle racing. In terms of GCR 84 (i), individual event supplementary regulations (SR's) may not conflict with these SSR's.
- iv) These Standing Supplementary Regulations may generally only be amended for safety reasons or as a result of force majeure.

2. CLASSIFICATION OF COMPETITIONS

Refer to GCR's 39 - 43, 50 and 56 - 61.

3. ORGANISING PERMITS

An application for a permit for a kart competition must be made in accordance with GCR 78.

4. CIRCUITS

- a) Two types of circuit will be approved, i.e. permanent and temporary. A permanent circuit is one the main features of which can only be changed by physical reconstruction. A temporary circuit is one defined by markings that can be readily moved.
- b) Plans for new circuit projects or modifications to existing circuits must be sent to the MSA Karting Commission for its approval prior to any works being undertaken. Failure to do so may result in the circuit/modifications not being approved by MSA.
- c) All new permanent circuits intending to stage national or international events were required to be built to conform fully to the CIK circuit regulations for at least a "C" grade circuit (in the case of national events), or the appropriate grade of CIK licence applicable for intended international events.
- d) A 1:500, or larger scale, dimensioned plan of every circuit shall be submitted to MSA. In the case of temporary circuits, a plan must accompany each application for a permit. In the case of permanent circuits, a dimensioned plan, drawn roughly to a scale of 1:500, or larger must be filed with MSA on application and, after inspection and approval of the circuit, a circuit licence will be issued at an annual fee. At least 8 weeks' advance notice must be given when applying for a permanent circuit licence.
- e) Measurement of circuit length shall be made along the right hand edge. Circuits used for karting events, whether permanent or temporary, must have a minimum length of 700 meters. For circuits built prior to 31.12.1984, a minimum length of 600 meters is permitted.

For permanent circuits built after 01.01.1985, the following are the minimum requirements:

i)	Length Minimum length Maximum length Non-gearbox classes Gearbox classes	700 meters 1500 meters No restrictions
ii)	Width Non-gearbox – minimum 125cc gearbox classes – minimum 250cc gearbox classes – minimum	6 meters 6 meters 8 meters
iii)	Maximum length of straights Non-gearbox classes Gearbox classes	170 meters No restriction

iv)	Surface – Asphalt or concrete around the whole length of	the circuit
-----	---	-------------

- f) **Circuit edges**
Both edges of a permanent circuit shall be clearly marked by a continuous painted yellow line at least 100mm wide, but not exceeding 150mm wide, and shall be laid in such a manner as not to constitute a hazard to competitors. There must be no drop between the edge of the circuit and the verge adjoining the circuit.
- g) **Kerbs**
Kerbs; at the point that they meet the track surface, should have a vertical rise of not more than 40mm above the circuit surface and shall have a slope to their outer edge not exceeding 5%.
- h) **Run-off areas**
All run-off areas shall be level and free of large stones, erosion gullies and other obstacles. All hazards to a kart leaving the circuit such as poles, ditches, etc. shall be cushioned or protected. Any object used as a marker shall be of such a size and weight that it will not constitute a hazard.
- i) **Spectator areas**
Where the current CIK specifications are not used the following will apply:
Spectator areas shall be separated from the circuit by efficient restrictive fencing, the minimum height of which shall be 1 meter. Such fencing shall be a minimum distance of 6 meters from the circuit edge on any straight and 8 meters on any corner. There must be a safety barrier (min. a tyre wall) on the circuit side of the fence, if the fence is less than 10 meters from the edge of the track.
- j) **Safety barriers**
Where the current CIK specifications are not used the following will apply:
Safety barriers will consist of tyres bound together in the prescribed manner (details of which are available from MSA on request). The tyres shall generally be stacked four high with one row overlapping the other by 50%. One row of the safety barrier shall be the minimum approved protection, unless otherwise stated. The face of the safety barrier shall not be less than 3 meters from the circuit edge, except in exceptional cases where MSA's circuit inspectors have approved to the contrary. Track owners are encouraged to face the tyre barriers with conveyor belting, suitably attached to the tyres with bolts. At points where karts may be expected to exceed 65 km/h the safety barrier shall consist of two rows, the rows being separated by a distance of 3 meters, unless the face of the tyre wall is protected with conveyor belting.
- k) **Enclosures: - Pits paddocks, constructions, clubhouses etc.**
Where the current CIK specifications are not used the following will apply:
No unprotected enclosure / construction shall be less than 20 meters from the circuit unless there is the approved type of tyre wall safety barrier between the enclosure and the circuit. Any enclosure / construction protected by a safety barrier shall not be less than 6 meters from the edge of the circuit and not less than 3 meters from the safety barrier, unless MSA's circuit inspectors have approved otherwise in exceptional cases.
- l) **Pits**
Where the current CIK specifications are not used the following will apply:
The pits shall be fenced and protected as are other enclosures, and shall have a firm surface. The entry to the pits from the circuit shall be immediately preceded by a chicane or bend to reduce the speed of a kart substantially. The width of the lane after the chicane shall be less than the width of two karts. There shall be an entrance to the circuit from the pits, controlled by officials.
- m) **Pre-race paddock**
There shall be an area in which karts can be assembled prior to a race. The pre- race paddock must be able to accommodate at least 34 karts. A line is to be painted across the pit road at a reasonable distance after the exit from the pre-race paddock but before entry onto circuit, to indicate the end of the pit lane.
- n) **Weighing area**
A covered, controlled area must be provided adjacent to the pit entrance for the weighing of karts. The entry lane leading to the weighing area, and the weighing area itself, must be controlled and access must be restricted to officials and relevant competitors only.
- o) **Parc Ferme**
The Parc Ferme shall be immediately adjacent to the weighing area, or connected to it in a manner capable of being controlled. Access to this area is restricted to accredited competitors and officials only.

- p) **Access**
Access to all enclosures, and to the circuit, shall only be by means of controlled entrances.
- q) **25-metre line**
A yellow line of 100mm to 150mm width must be painted across the width of the circuit 25 meters before the start line.
- r) **90-metre line**
A RED line of 100mm to 150mm wide must be painted across the width of the circuit not less than 90 meters before the start line.
- s) **Starting Grid**
Two pairs of continuous white lines, marking lanes 2m wide with an ideal minimum of 2m separating the two lanes must be painted for a maximum distance of 90m prior to the start line and with due consideration to the limitations of the circuit. (See FIA CIK Karting Circuits Appendix 10 for more details)
- t) The maximum number of starters will be determined as follows, unless otherwise stated on the circuit licence:
- | | | | |
|------|---|---|----|
| i) | Circuits up to 800m in length | | |
| | Bambino/Micro Class/Mini Classes | - | 30 |
| | All other Classes | - | 24 |
| ii) | Circuits from 800m to 999m in length | | |
| | Bambino/Micro/Mini Classes Max | - | 34 |
| | All other Classes | - | 30 |
| iii) | Circuits over 1000m in length | | |
| | All Classes | - | 34 |
- u) Circuits are inspected annually & must comply with all safety/facility requirements at least 7 weeks prior to the first scheduled national championship event.

5. CIRCUIT PLAN

The plan of the circuit to be submitted to MSA when applying for a circuit licence shall be to a scale of not less than 1:500, and shall indicate:

Start and finish

All enclosures and entrances

All safety / protective barriers Race control Flag marshal posts

Position of entry to and exit from the pits Pre-race paddock

Position of timekeepers and lap scorers Public address system Secretarial control

A Place for inspection by competitors to view practice times and race results (notice board) Assembly grid for 125cc shifter standing starts

Length of circuit showing maximum and minimum measurements

Type of surface, Medical facilities, Scrutineering area, weighing area, Welding area Parc Ferme for technical inspections and

Noise control area

Toilet facilities

Grandstands, Refreshment areas

Car parks for officials and competitors

6. OBLIGATORY CIRCUIT INSTALLATIONS

- a) The timekeeping, lap scoring, public address and secretarial areas must afford protection from the elements and be suitable for the intended purpose.
- b) The pits, pre-race paddock, weighing area, scrutineering bay, Parc Ferme to be of hard standing.
- c) Parking facilities for competitors and officials in close proximity to the circuit.
- d) Toilet facilities for males and females.
- e) Parc Ferme area/s capable of being secured.
- f) Secured welding area, complete with fire extinguishers of a capacity not less than 5kg, suitable for petrol and electrical fires.
- g) Electrical power should be available to competitors in the pit area.

7. THE FOLLOWING EQUIPMENT IS MANDATORY:

a) Signaling equipment as follows:

For the Clerk of the Course:

- i) Red flag, white flag, black flag with orange circle, black flag. Flag divided diagonally into black and white halves and a blue flag with red diagonal cross.
- ii) A set of white, non-reflective numbers not less than 300mm high by 170mm wide with a 30mm stroke, which can be

suitably mounted so as to be visible to competitors on the circuit. As an alternative, the numbers may be written clearly on a blackboard with white chalk.

b) For each Flag Marshal:

- i) Flags as per Appendix "H" of the MSA Handbook, and where applicable 15 x) of these regulations.

For the Starter:

- i) MSA flag, black and white chequered flag, green flag with yellow chevron (to signify a false start) blue flag, and blue flag with red diagonal crosses (to signify to a competitor that he or she has been/is about to be lapped) – refer Art. 15 x)
- ii) A lap display board for showing the competitors the number of laps remaining in the race.

c) For the Chief Paddock Marshal:

- i) A shrill whistle or hooter.
- ii) If their use has been approved by MSA, lights may be substituted for the starting flag [See Art. 18 (xiv)]
- iii) One blackboard and chalk or suitable means of writing and displaying notices (in the keeping of the Clerk of the Course).
- iv) A minimum of eight fire extinguishers with a combined capacity of at least 60kg, four of which must be in the paddock in an immediately visible position, the remaining four being strategically placed around the circuit. **All extinguishers must bear satisfactory evidence that they are in working order and/or that they have been serviced within the previous 12 months.** This clause shall apply to permanent kart circuits only. For street races and long-circuit races, the firefighting equipment is to be increased proportionately.
- v) Circuit cleaning equipment consisting of:
- a. Shovels
- b. Brooms
- c. Suitable cleaning agent for removing oil (cement may be used provided it is brushed off the circuit after use).
- vi) First aid equipment: Refer Appendix L in the MSA Handbook.
- vii) A public address system available to the Clerk of the Course and/or the Chief Paddock Marshal for communication with competitors (a hand-held megaphone is acceptable as a minimum).
- viii) A starter's sheet, under the control of the Secretary of the Meeting.
- ix) An official notice board prominently sited.
- x) A scale, suitable for the weighing of karts and with a current certificate of accuracy, as well as certified control weights totaling 100kg, which will serve to adjust the scale. **For national championship events the certificates of accuracy must be dated within 7 days prior to the commencement of the event.**

8. MSA PERMIT ISSUE

It is a requirement that any competition for karts as described in these regulations shall be held under a permit issued by MSA.

9. OFFICIALS

GCR 151 requires that at least the MSA Steward for National Championship events must hold a Clerk of the Course licence valid for karting. With effect from **01st July 2018**, this requirement (that the Stewards hold a Clerk of the Course licence) is extended to apply to **all** Stewards at **all** karting events, **excepting club events – see note below**. Penalties shall be imposed according to the respective series sporting regulations. Refer to the Rok and Rotax Sporting regulations.

If a competitor lodges a protest against another competitor, the Stewards will hear such protests as has always been the case.

Note: At club races the COC will impose penalties (after a hearing where applicable). These decisions may be protested.

A Clerk of the Course applying for an upgrade to an 'A' grade license must be approved by the MSA Karting Commission.

i) CHIEF COURSE MARSHAL:

In conjunction with GCR 170 and 171 shall be responsible for:

- ii) Ensuring with the aid of not less than four assistants, or the minimum as required according to MSA circuit safety inspection, that the track surface and marking and protective works are maintained in good order throughout the meeting.
- iii) Ensuring that the firefighting equipment is readily available and correctly sited and that his assistants and the paddock marshals are familiar with its operation.
- iv) Ensuring that the track-cleaning units are sited at suitable points.
- v) Supervising the removal from the track of any kart that may have stopped on the track. Karts may not be placed on the top of the tyre barriers.

vi) Supervising that all entrances to the track proper are manned and that no unauthorized person comes within this area. Normally more than four assistants will be required and, if enclosures are not surrounded by fencing, there must be Course Marshals stationed at strategic points between all enclosures and the track proper.

vii) **CHIEF PADDOCK MARSHAL**

- a. To maintain orderly conduct in the paddock and/or pit area.
- b. To notify competitors to assemble on the dummy grid prior to each heat or race.
- c. To ensure that no competing vehicle goes onto the circuit unless it has been approved by the Scrutineer(s).
- d. To exclude any unauthorized person from the paddock and/or pit area.

viii) **TEAM MANAGERS (for international events)**

Team managers may be nominated by MSA Karting Commission and will be solely responsible for the conduct of all members of the team, both on and off the circuit. This includes all assistants to the team drivers. All instructions given by the team manager to team members and assistants shall be firm and binding and his decision on a matter of policy, action or behaviour, shall be final. On completion of any international competition whether taking place in South Africa or in any other country, the team manager shall submit, in writing a full report on the performance and conduct of each team driver to the MSA Karting Commission and to the CEO, of MSA. This report shall be submitted within 21 days of the last day of the competition.

10. RIGHTS AND DUTIES OF ORGANISERS

Refer to Part VI of the GCR's. In addition, the following rules will apply:

i) Amalgamation of classes may take place in Club, Regional and National Championship events if there are less than 10 entries, subject to the proviso that:

- KZ or similar 6-speed karts may never be amalgamated with any other non gearbox class.
- Bambino class may never be combined with other classes under any circumstance.
- Kid ROK class may not be combined with other classes
- The Micro & Mini classes may be combined, provided they are scored separately within their own classes.
- Classes may only be combined with another class having similar age driver and similar performance. The status of the event is to be considered before combining classes in any way that might prejudice one another. All amalgamated classes must be scored separately.

Note; the amalgamation does not upgrade a competitor to a higher class and does not serve to help meet the minimum number of starters for any class for the purpose of eligibility for championship points.

Padding a class under the guise of amalgamation is not permitted.

A class will be deemed to have achieved the required minimum number of starters, and all races run on the day will score towards the relevant championship, if the class achieved the required minimum number of eligible starters in at least one of the races on the day.

ii) The organizers shall arrange that, in the event of drivers' start positions being determined by qualifying, such shall be carried out in accordance with Art. 18.

iii) With regard to the changing of drivers/equipment, the organizers may: Permit a change of driver(s) or make of kart or make of engine where permitted by regulations, from that nominated in the program, provided only a change of driver(s) or kart/engine is involved, and not both, and provided the request is made more than 30 minutes before qualifying practice or the first race in the event of there being no qualifying practice, and provided any such permission does not prevent the participation of a reserve entry. A kart shall not be driven by more than one nominated driver during an event or series of heats or races forming one competition except in an Enduro where more than one driver is permitted as per supplementary regulations.

Permit a change of chassis from the one originally submitted at pre-race scrutiny provided the request is made more than 30 minutes before qualifying practice or the first race in the event of there being no qualifying practice. In the event of a competitor's chassis being damaged beyond immediate repair as the result of an incident during practice, qualifying practice or any race, permit a change of chassis of any make for the following qualifying practice and/or races, provided the Clerk of the Course, in conjunction with the scrutineers, is satisfied as to the non-reparability of the chassis and the circumstances in which it was damaged. NOTE: Competitors in all classes shall be limited to the use of no more than two engines during any event. These engines are to be nominated and identified at scrutineering.

The same two (2) engines may not be nominated or used by different competitors. I.e. the inter-use of engines between competitors is not permitted.

iv) The organizers may specify fuel and/or provide fuel/oil and impose control measures as provided for in these regulations.

- v) The organizers shall display the remaining number of laps to the drivers during the race at Regional and National events.
- vi) Where a class already has National Status, a regional committee MAY grant it regional status without the need for Club status first.
- vii) Where footage is used by officials in the adjudication of any incident, a copy of the footage concerned must be kept for future use.

11. PENALTIES

a.) PENALTY FOR TECHNICAL INFRINGEMENTS

Notwithstanding anything stated to the contrary in MSA's General Competition Rules, (Specifically GCR 176) any contravention of the karting technical regulations or specifications will result in automatic exclusion from the relevant race (in circumstances where it can reasonably be assumed that the contravention applied to the specific race only) or from the entire event/race meeting (in all other cases).

Any component and or kart found not to comply with the technical regulations and specifications must be impounded by the relevant officials. The component may be returned to the competitor if the infringement is capable of being rectified (e.g. axle of kart too wide) but only after an admission of guilt form has been filled in, signed by the competitor and submitted to, and accepted by, the Clerk of the Course. It is the responsibility of the entrant/competitor to ensure that any component and or kart found not to comply with the technical regulations is impounded by the Technical Consultant. It is at the discretion of the Clerk of Course to decide whether to return a non-compliant part.

A competitor removing a part/kart from parc fermé that is deemed to be the subject of a technical infringement, as pronounced by the TC, without having signed an admission of guilt form, will automatically be excluded from the race concerned (if it is clear that the infringement was only in respect of the particular race) or from the entire race meeting (in all other instances). Any such exclusion shall be final, without the prospect of protest or appeal.

In the event of a dispute concerning any item/component/part not covered in the relevant regulations or specification sheets, the Technical Consultant shall be empowered to make a ruling as to whether or not a contravention exists and, if found that one does, to recommend an appropriate penalty other than exclusion for imposition by the Clerk of the Course.

Where a series/championship allows for race results to be "dropped" races from which a competitor has been excluded on technical grounds may be taken as "drops" when calculating the final series/championship standings, except in instances where the relevant race officials deem a technical infringement to have been a deliberate attempt at gain an advantage. In such cases, they may rule that the race/s from which the competitor has been excluded may not be 'dropped' and, in addition, may apply further penalties.

Where a formal appeal flows from a technical exclusion, at least 2 members of the panel installed by MSA to hear the appeal shall be individuals appointed by the MSA Karting Commission Exco on the basis of their experience and knowledge with regard to karting technical matters. The Technical Consultant's evidence shall be considered during the hearing of the appeal and may not be ignored – refer to the provisions of GCR 220 to the extent that they deal with appeals of a technical nature.

Competitors and/ or karts found to be underweight **will be excluded**. The lap times set in the heat will also be disregarded for grid positioning for the next race.

b.) NOSE CONE

The black flag with the orange disc will NOT be shown to a driver if his nose cone is no longer in the correct position. If an official reports that the nose cone on one or more karts is/was no longer in the correct position when the kart enters the exit lane to the scale/weighing area, in all situations a 5 second time penalty will be imposed automatically on the driver (s) concerned. This penalty cannot be protested. Should a driver be found to have replaced/realigned the nose cone which was not correctly positioned when entering the exit lane or after the chequered flag was waved, the correct penalty will apply as per the penalty schedule below. The tuning area is closed to drivers from the last lap board.

Photographic evidence of the nose cone dislodgement will be sent to the MSA Steward and will be deemed as irrefutable evidence in the issuing of a penalty.

Should a competitor's nose cone no longer be in the correct position at the end of Qualifying and or a race, the penalty applied will be as per the penalty schedule. Notwithstanding the provisions of GCR 175, this decision is non-protestable.:-

DESSIN TECHNIQUE N° 2d

Installation correcte du «Carénage Avant»

Position correcte / Correct position

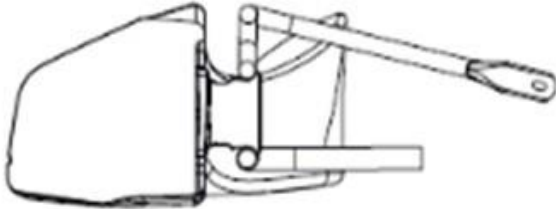

TECHNICAL DRAWING No. 2d

Correct installation of the "Front Fairing"

Position acceptable / Acceptable position

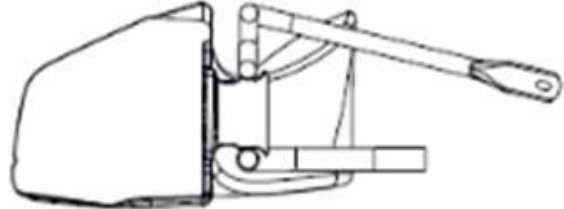

Position non acceptable si une quelconque partie des tubes du pare-chocs avant se trouve dans les zones marquées (A).

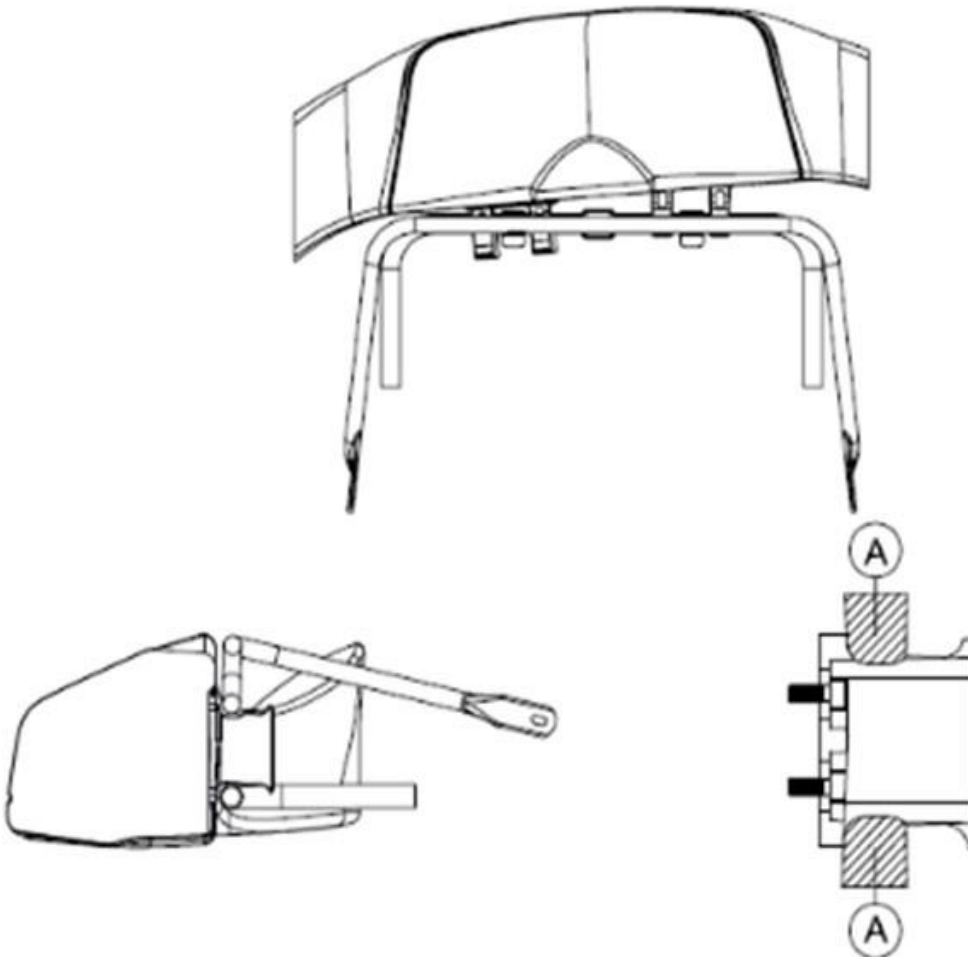

Not acceptable position if any part of the tubes of the front bumper are in the marked areas (A).



C. PENALTY SCHEDULE

DESCRIPTION		PENALTY
i)	Gaining an Unfair Advantage	5 seconds
ii)	Driving in a manner incompatible with general safety	10 seconds, Race or Meeting exclusion
iii)	Contravention of Yellow flag signal before or after Race -- Black/Yellow	3 place penalty
iv)	Contravention of flag signal during Race - Black/Yellow	3 place penalty
v)	Contravention of flag signal - Ignore Technical Flag Twice	Black Flag
vi)	Contravention of flag signal - Black Flag (ignored more than once)	Race or Meeting Exclusion
vii)	Abusive Language, Behavior or Assault	Race or Meeting exclusion
viii)	Failure to attend Drivers' Briefing	Fine of R 1 500
ix)	Failure to obey an Official of the Meeting	Race or Meeting exclusion
x)	Scrutineer Technical Non-Compliance Report, vehicle or component ineligible	Race or Meeting exclusion
xi)	Underweight	Race exclusion
xii)	Failure to report to Scrutineering	Race Meeting exclusion
xiii)	Incorrectly positioned front fairing - Qualifying practice	Deletion of fastest time
xiv)	Incorrectly positioned front fairing - race	5 Seconds penalty
xv)	Attempting to tamper with or reattach the front fairing during race / timed qualifying	Race exclusion
xv)	Intentionally reattaching the front fairing during timed qualifying, races and after chequered flag	Meeting exclusion & a one championship round ban

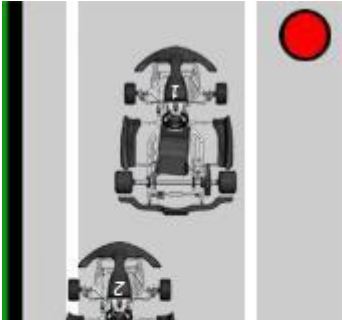
d.) PENALTY CATALOGUE

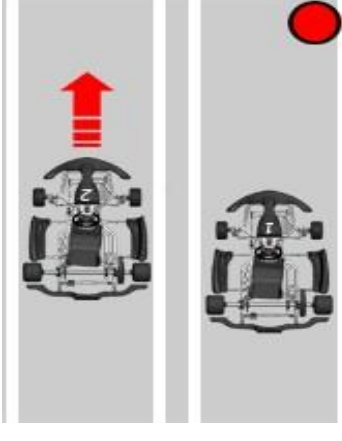
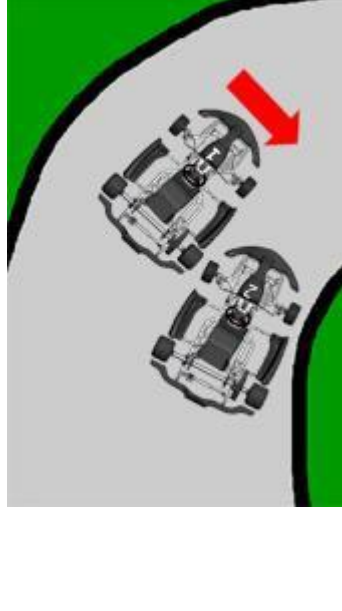
<p>FALSE START (Type A) means Kart 2 leaves the marked corridor during launch phase with at least two tyres before the start has been released. Leaving = the tyres are completely on or outside the corridorline.</p>		<p>General:</p> <p>A: 3 seconds B: 10 seconds</p> <p>Without advantage:</p> <p>Not relevant</p>
<p>FALSE START (Type B) means Kart 2 leaves the marked corridor during launch phase with at least four tyres before the start has been released. Leaving = the tyres are completely on or outside the corridorline.</p>		<p>With advantage:</p> <p>Not relevant</p>
<p>JUMP-START means that Kart 2 accelerates during launch phase leaving Kart 1 behind before start has been released. It is irrelevant if the start will be repeated afterwards.</p>		<p>General:</p> <p>5 seconds</p> <p>Without advantage:</p> <p>Not relevant</p> <p>With advantage:</p> <p>Not relevant</p>
<p>CUT-IN means that Kart 1 constricts the driveable section towards the curve centre forcing Kart 2 to leave the driveable section either partial or completely for passing the curve. It is irrelevant if the Karts have touched each other or not. A prerequisite is, however, that Kart 2 has to be at least 1/3 (front tyres next to rear tyres) next to Kart 1.</p> <p>An advantage is at hand, if (either/or):</p> <ul style="list-style-type: none"> - Kart 2 suffers a position loss or drop-out. - Kart 2 suffers a damage leading to a position loss or retirement within the same lap. 		<p>General:</p> <p>Not relevant</p> <p>Without advantage:</p> <p>5 seconds</p> <p>With advantage:</p> <p>5 positions</p>
<p>EDGE-INTO means that Kart 2 drives next to Kart 1 (e.g. in order to start an overtaking action) without possessing enough driveable section (including kerbs). It is irrelevant if Kart 2 is completely or partially next to Kart 1 or if Kart 2 is completely or</p>		<p>General:</p> <p>Not relevant</p> <p>Without advantage:</p>

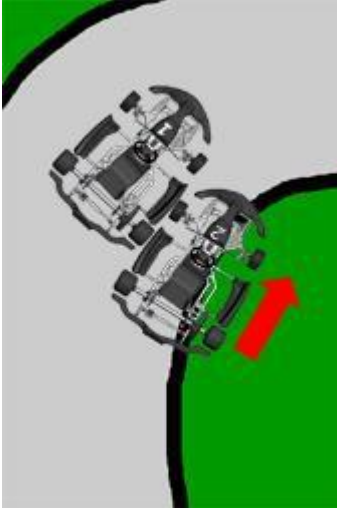
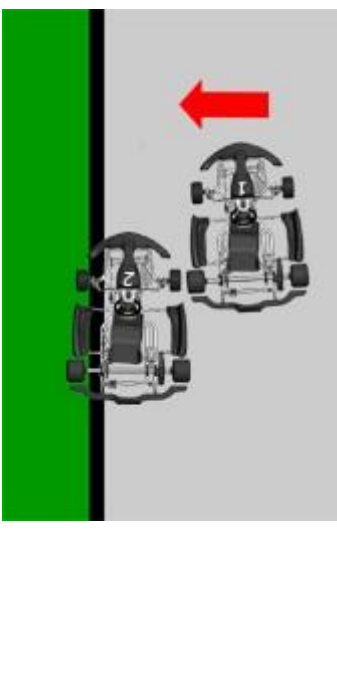
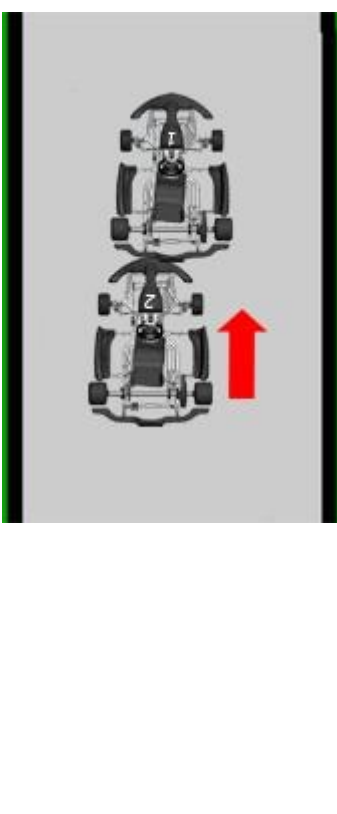
<p>partially off the track.</p> <p>An advantage is at hand, if (either/or):</p> <ul style="list-style-type: none"> - Kart 2 wins a position. - Kart 1 suffers a position loss or drop-out - Kart 1 suffers a damage leading to a position loss or retirement within the same lap. 		<p>5 seconds</p> <p>With advantage:</p> <p>5 positions</p>
<p>PUSH-OUT means if Kart 1 constricts the driveable section towards the outside line forcing Kart 2 to leave the driveable section either partial or completely. It is irrelevant if the Karts have touched each other or not. A prerequisite is, however, that Kart 2 has to be at least 1/3 (front tyres next to rear tyres) next to Kart 1.</p> <p>An advantage is at hand, if (either/or):</p> <ul style="list-style-type: none"> - Kart 1 wins a position. - Kart 2 suffers a position loss or retirement - Kart 2 suffers a damage leading in a position loss or retirement on the same lap. 		<p>General:</p> <p>Not relevant</p> <p>Without advantage:</p> <p>5 seconds</p> <p>With advantage:</p> <p>5 positions</p>
<p>BUMP means that the front of Kart 2 touches the rear of Kart 1. Neither the reason nor the intensity of the contact is relevant. Only the consequences of the impact are relevant to judge an advantage, not the impact itself.</p> <p>An advantage is at hand, if (either/or):</p> <ul style="list-style-type: none"> - Kart 2 wins a position and the previous order cannot be restored within the same lap. - Kart 1 suffers a position loss or retirement - Kart 1 suffers a damage leading in a position loss or retirement within the same lap. 		<p>General:</p> <p>Not relevant</p> <p>Without advantage:</p> <p>Warning only</p> <p>With advantage:</p> <p>5 positions</p>

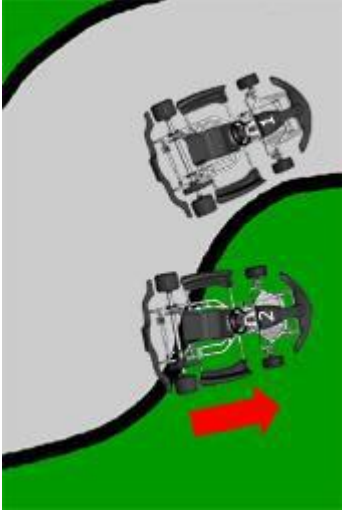
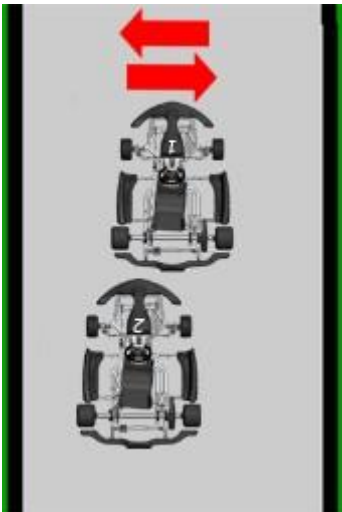
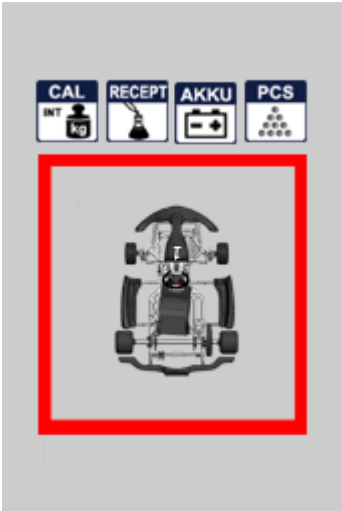
<p>SHORT-CUT means that Kart 2 leaves the track completely and returns to the track at a different section. It is irrelevant why Kart 2 has left the track.</p> <p>An advantage is at hand, if (either/or):</p> <ul style="list-style-type: none"> - Kart 2 wins a position or gains time which cannot be given back within the same lap. - Kart 1 or any other is handicapped by the return of Kart 2. - Kart 1 or any other suffers a position loss or retirement on the same lap by the return of Kart 2. 		<p>General:</p> <p>Not relevant</p> <p>Without advantage:</p> <p>Warning only</p> <p>With advantage:</p> <p>5 positions</p>
<p>ZIG-ZAG means that Kart 1 changes the driving line more than two times on a straight track section for more than a kart width. It is irrelevant how far Kart 1 is ahead of Kart 2 or if Kart 2 would have been able to overtake.</p> <p>An advantage is at hand, if (either/or):</p> <ul style="list-style-type: none"> - Kart 1 acts more than once a time this way within the same race. 		<p>General:</p> <p>Not relevant</p> <p>Without advantage:</p> <p>Warning only</p> <p>With advantage:</p> <p>5 positions</p>
<p>TECHNICAL NON-COMPLIANCE is at hand, if the Kart is not fulfilling the technical regulations in all parts. It is irrelevant, if the technical lack arises before, during or after the race. It is also irrelevant, if the technical lack would have led to an advantage or not. The only relevant thing is the technical condition at the time of examination.</p> <p>Typical examples for a technical non-compliances are:</p> <ul style="list-style-type: none"> - Under-weight - Wrong setup - Wrong fuel, oil,... - Modified parts etc. 		<p>General:</p> <p>Exclusion</p> <p>Without advantage:</p> <p>Not relevant</p> <p>With advantage:</p> <p>Not relevant</p>
<p>FORMATION FAULT is at hand, if Kart 2 improves it's starting position unforced</p>		<p>General:</p> <p>Exclusion</p>

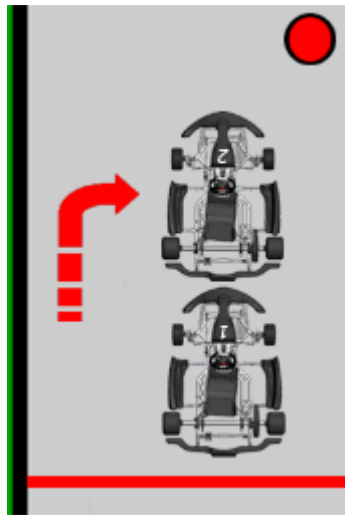
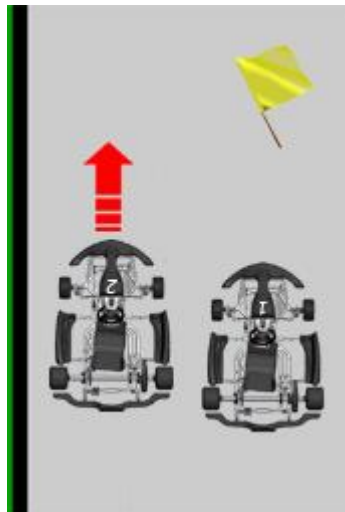
<p>during the formation lap after having crossed the „red line“ (and before the start has been released).</p>		<p>Without advantage:</p> <p>Not relevant</p> <p>With advantage:</p> <p>Not relevant</p>
<p>FLAG DISREGARD is at hand, if the driver does not carry out the flag instructions given by either the track personal or clerk of the course. It is irrelevant which flag is in question, why the flag has been disregarded or if the violation would have led to an advantage or not.</p> <p>Typical examples of a flag disregard are:</p> <ul style="list-style-type: none"> - Overtaking under yellow flag. - Continuing the race after receipt of black/orange flag. etc. 		<p>General:</p> <p>Exclusion</p> <p>Without advantage:</p> <p>Not relevant</p> <p>With advantage:</p> <p>Not relevant</p>

- 12. SCRUTINY**
 After an event, the Clerk of the Course may instruct that karts shall be placed in possession of the promoters/organisers for examination by the Scrutineers to determine if they comply with the regulations. Any kart failing to comply shall be dealt with in terms of the GCR's and Art 11 of these regulations. Refusal to submit a kart for scrutiny as directed shall result in automatic exclusion from the entire event and further disciplinary action. Any part found not to comply with the regulations, and which is incapable of being brought back into specification in a permitted manner, will be confiscated by the organisers to prevent its continued use.
- 13. SUPPLEMENTARY REGULATIONS**
 The promoters shall issue supplementary regulations in accordance with GCR 87 of the General Competition Rules of MSA.
- 14. AWARDS**
 Refer GCR281.
- 15. COMPETITORS – ENTRANT REQUIREMENTS**
 The following regulations are supplementary to the General Competition Rules of MSA.
- The provisions of GCR 22 notwithstanding, in karting should a parent or court appointed legal guardian not be in a position to act as the entrant for his or her minor child, he or she may nominate another parent/legal guardian whose minor child is taking part in the same event/s or, alternatively, an adult competitor taking part in the same event, to act as his/her entrant by proxy. To be valid, any such proxy nomination must be submitted, in writing and signed by the parent/legal guardian appointing the proxy, to the Race Secretary for the relevant event/s prior to the commencement of competition.
- An adult competitor may appoint another adult competitor competing in the same event to act as his/her entrant. Subject to what is set out below in order for that appointment to be valid, that appointment must be submitted in writing recording the reasons for the appointment and signed by the adult competitor appointing another adult competitor to act on behalf of his/her behalf to the Race Secretary for the relevant event prior to the commencement of the event.

For the purposes of this Regulation, an adult competitor excludes any person/s or body deemed to be a competitor (as envisaged in GCR 19) as a consequence of being an entrant in terms of GCR 22.

The Stewards and/or the Clerk of the Course shall be entitled to investigate the reasons why a parent/legal guardian and/or an adult competitor is not in a position to act either for himself/herself or for his/her minor child as an entrant. The Stewards and/or the Clerk of the Course shall in their sole and absolute discretion be entitled to accept and/or reject the appointment of either the third party nominated to act for a minor child or an adult competitor nominated to act for another adult competitor

It is the entrant's responsibility to ensure that all persons concerned by his entry observe all the provisions of the code, the technical regulations and the sporting regulations.

The person having charge of an entered kart during any part of an event is responsible jointly with the entrant and/or separately for ensuring that the provisions are observed.

Entrants must ensure that their karts comply with the conditions of conformity and safety throughout the Event.

The presentation of a kart for scrutineering will be deemed an implicit statement of conformity.

Entrants, drivers, assistants and guests must at all times wear the appropriate identification credentials which have been provided to them.

i) **LICENCES**

- Club licences (only valid for classes/events having club status) or Regional licences will be issued to **all new applicants by MSA and will only be exchanged for a full national licence after the holder has competed in three events under observation and has satisfied the Clerk of the Course after the third event by way of a short examination that he/she is conversant with the basic kart racing regulations. Passing the examination will qualify the holder for a national licence on application to MSA.** All holders of regional licences who have not yet passed the examination referred to above shall wear a prominent cross on the back of their helmets in a colour contrasting with that of the helmet to warn other competitors of their novice status.
- All competitors under 18 years of age must have their kart license application forms countersigned by a parent, or legal guardian, who must also approve and countersign their competition entry form.
- Junior competitors are required to submit satisfactory proof of their ages, together with their licence applications. Note: A karting competition licence is only valid for events that are confined to kart racing.
- In order to be issued with a licence, competitors must be able to provide proof of current membership of an MSA-affiliated karting club.

ii) **TYPES OF LICENCES**

- **Club licence**
A Club license is only valid for events of club status.
- **Regional licence**
Valid for all Regional and Club events.
- **National licence**
Valid for all National, Regional and Club events.
- **International Licence**
Issued at the discretion of MSA to competitors deemed suitably qualified and experienced.

iii) **AGE LIMITS**

There are two distinct karting series namely the SA Rotax Max Challenge and the Rok Cup SA and each offers classes for a variety of age groups. The details of these series can be found in the specific series Standing Supplementary Regulations published on the MSA Website

Briefly the classes offered are:

SA Rotax Max Challenge Series:

- **Bambino (National Championship)**
Open to all drivers from the year of their 5th birthday, to 31 December of the year in which their 9th birthday occurs.
Minimum weight for the kart, including driver and all required safety equipment (helmet, overall, gloves etc): **74Kg**
- **Micro Max (National Championship)**
Open to all drivers from the year of their 7th birthday to 31 December of the year in which their 12th birthday occurs
Minimum weight for the kart, including driver and all required safety equipment (helmet, overall, gloves etc): **105Kg**
- **Mini Max: (National Championship)**
Open to all drivers from the year of their 9th birthday, to 31 December of the year in which their 13th birthday occurs.
Minimum weight for the kart, including driver and all required safety equipment (helmet, overall, gloves etc) **118kg**
- **Rotax Junior Max: (National Championship)**
Open to all drivers from the year of their 12th birthday, to 31 December of the year in which their 15th birthday occurs.
There is no upper age restriction for female competitors; however, qualification for the RMGF is restricted to the published age for this class. Minimum weight for the kart, including driver and all required safety equipment (helmet, overall, gloves etc) **145kg**
- **Rotax Senior Max (National Championship)**
Open to all drivers from the year of their 14th birthday. Minimum weight for the kart, including driver and all required safety equipment (helmet, overall, gloves etc) **160kg**
- **Master Max (Regional Championship)**
Open to drivers from the year of their 16th birthday who weigh more than 85kg in their shorts on race-day and open to all drivers from the year in which the 32 birthday occurs.
Minimum weight for the kart, including driver and all required safety equipment (helmet, overall, gloves etc) **180Kg**
- **Rotax DD2: (National Championship)**
Open to all drivers from the year of their 15th birthday. Minimum weight for the kart, including driver and all required safety equipment (helmet, overall, gloves etc) **174kg**
- **Rotax DD2 Masters: (National Championship)**
Open to all drivers from the year in which their 32nd birthday occurs, and to drivers over the age of 15 who weigh more than 85kg in their shorts. Minimum weight for the kart, including driver and all required safety equipment (helmet, overall, gloves etc) **180kg**

Rok Cup SA

Minimum weight: Refer to ROK series sporting regulations.

- **Kid RoK (National Championship)**
Open to all drivers from the year of their 6th birthday to 31 December of the year in which their 10th birthday occurs.
Minimum weight for the kart, including driver and all required safety equipment (helmet, overall, gloves etc) **95kg**
- **Mini Rok: (National Championship)**
Open to all drivers from the year of their 8th birthday, to 31 December of the year in which their 13th birthday occurs.
Minimum weight for the kart, including driver and all required safety equipment (helmet, overall, gloves etc) **110kg**

OKJ (National Championship) Drivers who are at least 12 years old (or who reach their 12th birthday during the year) and 15 years old as a maximum (not reaching their 16th birthday before 31 December of the year concerned). Open to all female drivers at least 12 years old (or who reach their 12th birthday during the year) no upper age limit. Minimum weight for the kart, including driver and all required safety equipment (helmet, overall, gloves etc) **142kg**

Super Rok/DVS (Club Championship) Open to all drivers from the year of their 15th birthday. Minimum weight for the kart, including driver and all required safety equipment (helmet, overall, gloves etc) **155kg**

KZ2 Shifter (National Championship) – Open to all drivers from the year of their 15th birthday. Championship will be scored on overall classification and not per class. Minimum weight for the kart, including driver and all required safety equipment (helmet, overall, gloves etc) **182kg**

- **KZ & KZ Masters Shifter (Interprovincial Championship)** – KZ Class open to all drivers from the year of their 26th birthday. KZ Masters Class open to all competitors from the year of their 38th birthday. Minimum weight for the kart, including driver and all required safety equipment (helmet, overall, gloves etc) **TM KZ10 195kg, TM KZ10C 200kg.**

- **KZ2 Shifter Class (Regional Championship)** ~~as a sub-class to KZ,~~ is open to all drivers from the year of their 15th birthday.

The details of these series can be found in the specific series Standing Supplementary Regulations published on the MSA Website

iv) **SAFETY CLOTHING**

Drivers shall wear, both during official and unofficial practice and during all racing, a properly positioned and secured crash helmet, see d) below, with splinter proof goggles or visor in position. In addition, gloves that cover the hands completely, and a protective one-piece race suit must be worn. Boots and socks must be worn adequate to cover and protect the ankles. For all competitors younger than 13 years of age, suitable neck braces and chest guards are recommended.

- **SUITS**

Suits must have a CIK homologation number or MSA approval.

- **HELMETS**

All drivers must wear a helmet with efficient and unbreakable protection for the eyes. All helmets must comply with the DOT, SNELL, ECE or CMR specifications approved for the following categories of motorsport; Cars, Motorcycle and Karts. All helmets must have chin protection (Full-face helmet). It is highly recommended that drivers of the age 15 and younger use CMR specification helmets.

The use of Helmets 10 years after their date of manufacture is not permitted. All labels and markings indicating specifications and date of manufacture must be clearly visible. Event officials may request a competitor to provide proof that the helmet does comply with requirements as set out in this regulation.

Drivers must at all times secure all loose straps or flaps around the helmet base and neck area, including neck brace and overall straps. If doubt exists with officials as to whether a helmet strap is fastened correctly, then the competitor will receive a black & orange flag. Once the competitor has secured the helmet and /or loose straps then he/she will be allowed to return to the circuit.

v) **DRIVERS BRIEFING**

If it is stated in the supplementary regulations that a drivers' briefing is to be held prior to the commencement of racing, **it is compulsory for all competitors to attend.** Failure to attend drivers briefing and not excusing themselves may result in a fine of R1500.00.

vi) **SAFETY PROCEDURES**

ENTERING PITS

- It is compulsory for all drivers to stop and cut their engines at the entrance to the paddock areas. Failure to observe this rule may result in a fine of R750.00.
- During both practice (unofficial and official) and racing, drivers intending to leave the track to enter the paddocks or pits **MUST INDICATE THEIR INTENTION BY RAISING ONE ARM. THEY MUST LEAVE THE TRACK ON THE SIDE THAT WILL GIVE THEM AN UNINTERRUPTED RUN INTO THE PIT OR PADDOCK ENTRANCE WITHOUT CROSSING THE PATH OF A FOLLOWING KART.**

vii) **CONDUCT**

- All persons shall conduct themselves in an orderly manner. Any disorderly conduct or any failure to obey official instructions or any breach of these regulations by entrants, drivers, or their assistants, shall make the entrant concerned liable to a penalty and/or fine.
- All participants must play within the rules and respect race officials and their decisions.
- All participants must respect the rights, dignity and value of their fellow participants regardless of gender, ability, physical appearance, cultural background or religion.
- All participants must encourage and take responsibility for their actions at all times.
- All participants must ensure their equipment is safe and race worthy, prior to taking part in training, testing or race events. Only approved racewear (e.g.: helmet, gloves, race boots and suit) to be used by the driver, according to the regulations.
- It is the participants own responsibility to identify and measure his/her own skill level against his/her competitors, and take responsibility for the risks associated with training, testing and or racing. It should be noted that a basic level of competence is required.
- It is the participant's responsibility to declare, prior to any participation in training, testing or racing, of any medical condition or medication required that may be relevant in the event of an emergency.

- All participants are required to display courtesy and etiquette to other members and participants in training, testing and race events. Any disputes or problems that may arise during an event must be addressed in a respectful manner, to the correct person (official) at the event.
- The safety of children within the sport is a priority. Knowledge of the code of ethics surrounding care of children in sports will be promoted and encouraged. It is the participant's own responsibility to ensure the safety of children at training, testing or racing events.
- When taking part in any event, it is the responsibility of the driver to take the time to read and fully understand the posted rules, regulations and conditions for said event prior to start time, thus eliminating unnecessary delays at the beginning of the event. Requests for clarification of these rules, regulations or conditions, should be asked in the drivers meeting held before each event.
- All participants must have respect for the environment and the surrounding inhabitants. Responsibility must be taken to reduce excessive noise and keep all areas that are used as clean and pollution free as possible.
- All participants must respect that drugs and alcohol are strictly prohibited at training, testing and races. It is an offence and will not be tolerated. Offenders will be excluded from the event and face further disciplinary action.
- Any abusive comments on social media (Facebook, Twitter etc.) between teams, competitors, officials, organizers, will be held responsible and liable for their actions.
- If the offence occurs during a race, the kart and driver concerned may be excluded from the race, or entire event and/or a penalty and/or a fine may be imposed. Failure to report at a specified time shall be a breach of the regulations and may be subject to a penalty and/or a fine.
- Wild or disorderly driving shall be subject to exclusion.
- Any proceeding, derogatory action, or interference with or against a race official by entrants, drivers, or their assistants shall be considered a breach of GCR 172 (iv) and shall make the entrant liable to a penalty and/or a fine. (Refer to GCR 121 for the definition of responsibility).
- Abuse of officials – refer GCR 172 (x).

viii) **DESIGNATED REVVING AREA**

To avoid excessive noise and exhaust emissions revving the engine in the servicing park is not allowed (except a short function test – 5 seconds maximum)

Competitors are advised that organizers and officials will now strictly enforce this regulation and to accommodate those wishing to “REV” or warm up their engines the following points will apply:

- “Servicing park” is defined as any area or surrounding the pits, access roads, parc ferme or pre-race grid.
- Each circuit will have a defined “REVVING” area and this will be the only place where tests of longer than 5 (five) seconds are permitted.
- An additional warm up lap will be provided for Micro and Mini Max (two warm-up and one formation lap before the start) to ensure that warming up engines in the pits is no longer required.
- A fine of R 500 for a first offence will be imposed for any breach of these regulations. Any subsequent transgressions will be penalized at the discretion of the race officials.
- A statement from any signed on official of the event is the only evidence required for the imposition of a penalty.

ix) **WITHDRAWAL FROM AN EVENT OR RACE**

Refer GCR110.

x) **FIRE EXTINGUISHERS**

Each competitor shall be required to present a dry powder fire extinguisher at pre-race scrutiny. The extinguisher must be of at least 1,5kg capacity and be marked in a permanent fashion with the competitor's name and competition number. It must bear evidence of having been serviced within the previous 12 months.

xi) **FLAGS**

Flag signals will be per Appendix H and in addition

- A green flag with yellow chevron will be used to signal a false start.
- A green flag may also be used, if necessary to signal the start of warm up laps, or the start of practice sessions by order of the Clerk of the Course. It is not obligatory that this flag will be displayed after showing the yellow flag to indicate the track is clear of any dangerous situation, provided the supplementary regulations state that the green flag will not be displayed in such situations.
- If provided for in the SR's, a blue flag with red diagonal crosses used in conjunction with a signal board displaying a competitor's number, will signify that the competitor must stop as he/she has been lapped or is about to be lapped.

xii) **TIMEKEEPING AND TRANSPONDERS**

- Only timing systems approved by the MSA Karting Commission may be used for all karting events. Competitors at SA National Kart Racing Championships need to supply their own transponders (whether purchased or rented). Transponders will no longer be supplied by the organisers. Competitors MUST ensure their own transponders are properly charged and fitted by the 3rd practice session of a SA National Championship event. Timekeepers are not responsible for unrecorded times, particularly due to low battery transponders.
- Competitors at Club and regional events will not be required to have their own transponders.

16. VEHICLES - GENERAL

- i) All karts must satisfy the Scrutineers of the meeting as to their suitability for racing, taking into account all details of their design and construction. In addition, it must be evident, both from a static examination and from its behavior on the track, that a kart will present no hazard to the driver or to other competitors or to spectators. Checks may be carried out at any time to ensure that only permitted chassis are being raced.

ii) **ADDITIONAL REQUIREMENTS FOR KARTS COMPETING OTHER THAN AT KART TRACKS**

MSA may permit karts to compete on a course used for other types of racing and speed events having different rules and regulations. In such a case the MSA Scrutineers of the Meeting shall be satisfied that in addition to complying with MSA kart specifications above, and further requirements hereafter, the design and construction of the karts and their accessories are suitable for the event particularly in respect of strength. When competing in such conditions karts shall be exempted from complying with MSA vehicle regulations for cars, provided the MSA Scrutineer is satisfied with the soundness of the general construction of the karts. In particular, stub axles and steering components shall be of adequate strength and proper design. Karts shall be fitted with adequate brakes on at least both rear wheels. Tyres of an industrial type shall not be used. In addition, the handling and steering characteristics of all karts shall be such, in relation to the course, that no particular hazard is created.

iii) **RACING NUMBERS**

- Each kart shall be identified prior to scrutineering by opaque flexible plastic number plates affixed to the kart itself and facing front and to the rear.

Bibs & rear bumpers:

Bambino	10cm (100mm) minimum
Kid Rok, Micro Max, Mini Max and Mini Rok	12cm (120mm) minimum
All other Classes	14cm (140mm) minimum

Note - the backing must be of a uniform single colour as defined in these regulations. The numbers must be standard font "ARIAL" and in an unbroken colour without borders, edging or shadow.

SA Rotax Series classes:

- BAMBINO class will use black numbers on a yellow background. 1 to 99
- MICRO MAX class will use black numbers on a yellow background. 601 to 699
- ROTAX MINI MAX will use white numbers on a blue background. 501 to 599
- ROTAX JUNIOR MAX karts will use white numbers on a green background. 401 to 499
- ROTAX Senior MAX will use white numbers on a black background. 201 to 299
- MASTER MAX will use black numbers on a white background. 301 to 399
- ROTAX DD2 will use white numbers on a red background 1 to 99
- ROTAX DD2 Masters will use black numbers on a white background 101 to 199

ROK Categories and KZ KZ2 Classes:

- All Classes Black numbers displayed on a yellow backing.
- KZ Masters class will use white numbers on a red background.

For the purpose of TV coverage, marketing and timekeeping all race numbers must be bold upright (no italics) font similar to ARIAL. Script type numbers are not permitted. Neither neon coloured numbers and or backgrounds are permitted.

- Competition numbers must be present and legible on the side pods in the same upright bold fonts as above. The backing on for these side pod numbers can be either the standard yellow or the class colour. No other colours are permitted. For the purpose of TV & marketing, the recommended size for these side numbers is 80mm.

iv) **NUMBERS**

The first 10 Racing Numbers in each class eg: 401 to 410 will be reserved for the top ten finishers in the previous year's SA Championship for the particular class. All racing numbers shall be allocated by and be obtained from MSA on a first come first served basis. Consideration will be given to competitors who actively used the number in the previous season. Numbers not booked by the first race of the season will be released.

17. PRACTICING

- a. On each day of an event, before racing commences, a definite period or periods shall be allotted for practicing. For club and regional championship events, the minimum free practice time shall be one 5 minute session, for each class. All regulations and requirements applicable to racing except for the starting procedure, shall apply to practice. **Should an event be run over two days, free practice on the second day may be substituted by qualifying.**
- b. Each driver shall complete at least three laps continuous running in practice at each meeting before taking part in a race. The COC can waive this requirement for an experienced driver
- c. Classes shall generally practice separately but classes of similar performance may be grouped together where deemed necessary. The proviso in this regard is that the number of karts shall not exceed the maximum permitted for the track. Refer also Art. 10 i)
- d. Bambino **must** always practice separately from all other classes and may not be combined with any other class
- e. Kid Rok **must** practice and race separately always
- f. 6-Speed gearbox karts must practice separately from all non-gearbox karts.
- g. Drivers shall exit the paddock and/or enter the track in such a fashion so as not to compromise safety.

18. RACING – GENERAL REGULATIONS AND FORMAT APPLICABLE TO ALL COMPETITIONS

- i) In the interest of safety, before a kart proceeds onto the track for timed laps or races, a check shall be made that it has been passed by the Scrutineers.
- ii) Only the officially nominated driver shall drive a kart on the track during pre-race practice and racing, except with the specific permission of the Clerk of the Course.
- iii) Methods for starting shall be:
- A rolling start for non-gearbox classes, except for Bambino Class, where a standing start is an option
 - A standing start, with engines running, for gearbox classes. Organizers may use a rolling start provided this is clearly laid down in the SR's for the event. (A 'Le Mans' type start is prohibited).
 - The Organisers reserve the right to start the Bambino's under 'Pace Kart' conditions where a Pace Kart will be utilised for this purpose."
- iv) For all classes, the karts will be assembled in 2 parallel rows.
- v) The order in which the karts shall be started will be determined by:
- Ballot,
 - Qualifying, which shall consist of either a 10-minute practice session where each lap is timed for every driver or, alternatively, two timed laps preceded by a warm-up lap for each driver, i.e. 1 warm up & two flying laps. The time of each driver's best lap will count for grid position, the second-best lap time being used to separate any possible ties.
 - The fastest time set in a preceding heat may determine the grid for the subsequent races
 - **Any driver deliberately jeopardizing another driver's lap time will be penalized accordingly.**
 - Qualifying and starting grids may be defined in the individual series SSR's for Rotax or Rok
 - In respect of the 10minute timed session, drivers who stop or spin off and cannot restart themselves and who, at that stage have not recorded three timed laps may apply for extra timed laps – at the COC's sole discretion.
 - In the above case (10minute timed session), approval of the application for additional timed laps will be at the discretion of the Clerk of the Course.
 - Where qualifying is based on the "10minute session" method, a re-run granted will only consist of one warm-up and two timed laps
 - Karts to be used for a re-run must remain in Parc Ferme between runs under the supervision of a scrutineer, i.e. no work may be carried out between runs.
 - The method of determining grids must be published in the relevant championship regulations and/or event SR's.
 - Each kart will be allocated a starting position on the pre-race grid. The places of non- starters will be left empty, the other competitors retaining their allocated positions.
 - Protests regarding start positions must be carried out in accordance with Part IX of the MSA Handbook.
 - Pole position will be on the side of the track corresponding to the inside of the first corner after the start.
 -
- vi) **ROLLING STARTS**
- On display of the green flag indicating that karts are under starter's orders, the karts will leave the pre-race paddock and proceed in two parallel rows in grid order directly to the 90 metre steady speed point (see below) or complete a lap or

part thereof as instructed by the Clerk of the Course depending upon the nature of the circuit or the size of the field. No further karts will be allowed out of the pre-race paddock onto the circuit once the start signal has been given and the race has begun.

A steady speed point must be indicated by a RED line and/or markers on either side of the track at a suitable point (within the ambits of the circuit). But not less than 90 meters before the start line, and when the pole position driver reaches this point, he must set and maintain a reasonable and constant speed slow enough to allow the field to form and bunch up and the driver in No 2 position must at this stage without delay position himself level with the pole driver. The rest of the field must then bunch up in their allocated positions behind the two leading drivers, in two parallel lines. A driver, who is unable to take up his correct grid position prior to the field reaching the 90 meters' steady point, must take up position at the rear of the field. The No 2 driver must maintain position level or slightly behind the pole driver as they approach the start line. At any point between the 25-meter line and the start line, when the two leading karts are level, or the pole man is slightly ahead and the majority of the field is in position, well bunched up and in two parallel lines, the starter may give the starting signal. Until the signal to start is given the entire field will remain in grid order one behind the other and it is forbidden to move either to the left or the right or leave more than one kart length behind the kart in front.

Should the Starter or the Clerk of the Course not be satisfied with the disposition of the field as the leading karts approach the start line, it may be indicated that the field must complete another warm up lap, or a false start may be notified to the drivers by means of showing the false start flag (green with yellow chevron). Drivers will then proceed round the circuit and repeat the starting procedure. Should the start signal have been given and the race has in fact begun, then any competitor guilty of a starting offence may be penalised and will be notified accordingly after the race. The onus is on each competitor to ensure that he/she complies with the starting procedure. In the event of the pole driver not being able to take up his correct position, the No 2 driver will be responsible for setting the pace from the Red 90-meter steady point. If either of the front row grid positions are vacant as the field approaches the start line, then the starter may start the race based on the position of the remaining front row kart(s) alone.

- Any penalty imposed as a result of the above, must be advised to the competitor after completion of the race or heat and must be deducted immediately from the driver's accumulated points for the day following a hearing.

vii) **STANDING STARTS**

On display of the green flag, the karts will proceed at an orderly pace to the dummy or starting grid where they will stop in either staggered or parallel formation as defined in the SR's with engines running and in their allocated positions when the Clerk of the Course will signal the starter to start the race. Should the Clerk of the Course be dissatisfied with the disposition of the field for any reason he may send them round for another lap after which they will reform again on the grid. Any driver who is not stationary at the moment the starting flag is raised, must stop immediately. A place penalty of 5 places for the first offence, then 8 places for the second offence and then exclusion for the third offence shall be imposed by the Clerk of the Course, should any of the following actions occur which will be classed as starting offences should the start signal have been given:

- Starting further forward than the allocated grid position or ahead of the demarcated line on the
- Moving prior to the start signal being shown.
- The imposition of a penalty as a result of the above must be advised to the competitor after completion of the race or heat, and the race results must be immediately amended accordingly to allow the driver's accumulated points for the day to be calculated correctly.
- In the case of handicaps, competitors may be started individually or in groups, according to their allotted handicaps.

viii) **SIGNAL TO START A RACE**

A race shall be started by the lowering of the MSA flag or alternatively by the extinguishing of the red light/s. In the latter case, a red light/s must be mounted directly above the circuit and must be visible from any point on the starting grid. Illumination of the red light will correspond to the raising of the start flag, being followed by extinguishing of the light/s to start the race. In the use of flag starts, the starter may be positioned beside the track but may not start the race from any position upon the tarmac of the circuit. **It is obligatory to state in the supplementary regulations if lights are to be used.** In the case of a false start, the Clerk of the Course may have the field return to the pre-race paddock and penalise the guilty driver accordingly. Should the Clerk of the Course allow the field to reform for another lap and a starting offence is again committed, the race will continue and the guilty party **shall** be penalised accordingly after the end of the race. Should a penalty be imposed, that penalty will be a place penalty of 5 places for the first offence, then 8 places for the second offence and then exclusion for the third offence. Any penalty imposed as a result of the above must be advised to the competitor with a hearing after completion of the race or heat and the race results must be immediately amended to allow the driver's accumulated points for the day to be calculated correctly.

ix) **SIGNAL TO FINISH THE RACE**

It shall be obligatory for the checkered flag to be shown after the last lap board. After receiving the end of the race (or practice) signal, which shall be the displaying of the chequered flag, each driver shall continue at a reduced speed to the

paddock entrance. If, during a race, the chequered flag is inadvertently displayed before the race is scheduled to end (in terms of the SR's or as amended), the race will nevertheless be deemed to have ended. If, during a race, the chequered flag is inadvertently displayed after the race is scheduled to end, the race will nevertheless be deemed to have ended when it was due to end.

x) **CLASSIFICATION OF A FINISHER**

After the winner has received the chequered flag, any driver who has not completed the full number of provided laps, even if he does not finish the race, will be classified according to the number of laps he has actually covered, provided he has completed at least two thirds of the race distance (rounded down to the nearest whole number of laps). No kart may be pushed over the finish line. For the resolving of Ties refer to article 19 ii).

xi) Any handicap shall be based on an allowance of time or distance determined by: a) individually timed performance in practice or a preceding race, or b) an assessment of performance by the organisers. The method of handicapping, if any, shall be stated in the Supplementary Regulations.

xii) Refueling during a race is forbidden, unless permitted by the Supplementary Regulations. Whenever a kart is refueled at the pits, the engine shall be stopped throughout the refueling operation, and the driver shall vacate his kart. No entrant shall have any one container in the pits holding more than 25 liters of fuel.

xiii) **STOPPING THE RACE**

Should it be deemed necessary to stop the race due to an accident on the grounds of safety or for any other reason, the RED FLAG shall be shown by the Clerk of the Course and all flag Marshals shall show red flags to indicate the race has been stopped. All drivers will immediately stop racing and continue slowly to the start line, being prepared to stop at any point if requested to do so by an official. On reaching the start line, the competitors shall be required to stop. The results will be formulated as follows:

- Should less than two (2) laps have been completed the race shall be re-run and the first start declared null and void. Only the original drivers will be entitled to take part in the restart, and they will take up their original start positions. The restart time will be at the discretion of the Clerk of the Course.
- Should the race be stopped between laps three (3) and 67% of the total race distance, the race will be restarted based on the finishing order of drivers the lap preceding the stopping. The restart time, if delayed, will be at the discretion of the Clerk of the Course.
- Should 67% have been completed it shall be deemed a race and the result will be the finishing order at the end of the lap preceding the stopping.

xiv) **TELEMETRY/DATA LOGGING / RADIO COMMUNICATION**

Any form of telemetry or radio communication with the kart or driver, while they are in motion on the track, is prohibited, during official practice, qualifying and races. However, data logging for the purpose of later down loading as specified in the series regulations only is permitted

xv) **On Board Cameras**

Competitors wishing to carry on-board cameras or any race recording devices:

- Recording devices (Go-Pro's) may only be mounted with the standard brackets (as supplied with the unit) to the kart's plastic side pods, front and rear bumper or bib and on top of the radiator. **No** additional mounting extension between the kart and the recording device is permitted.
- A maximum of two recording devices is allowed per kart. It is **NOT** permitted to mount any device on the helmet.
- Ensure these are adequately and securely fitted to their karts for inspection at scrutineering and at any time during an event.
- Declare their intention to use a camera on their entry form.
- Make available all camera footage to officials on demand

xvi) **Weighing Scale**

- The weight of the karts shall be adjudged as they crossed the finish line at the end of the practice session or race, i.e. any part lost off the kart after the finish line may be weighed together with the kart.
- It is compulsory after qualifying and after each race for all drivers and their karts in all classes to be weighed prior to entering the paddock. The penalty for being underweight is exclusion.
Scale of the day will be the instrument to be used. Refer Art 7 j)

THE DISPLAYED WEIGHT IS THE ONLY NUMBER CONSIDERED – NO TOLERANCE OR LATITUDE IS TO BE GRANTED BY SCALE ATTENDANTS

- Karts **MAY NEVER** be driven onto the scale and must always be pushed.
A kart will only be weighed once and the weight recorded accordingly. Any dispute will be referred to the COC immediately by the scale attendant and the kart in question and driver will be asked to stand in a quarantined area with no outside interference. Failure to comply with this requirement will result in exclusion.

xvii) **Recovery**

In case of a breakdown no outside assistance will be allowed except by the designated recovery vehicle.

xviii) **Practicing – Art.17**

xix) **Identification of equipment**

- Immediately after the qualifying session weigh-in, engines must be sealed or identified in a suitable manner to enable the Scrutineers to carry out a post-race examination effectively. Other additional seals or identification procedures may be utilized by the scrutineers at any other time throughout the event. For ALL classes, engines may be required to be sealed and their carburetors and exhaust silencers suitably identified. Details in this regard shall be incorporated in the supplementary regulations for each event. Rok classes need to ensure that the cylinder head and cylinder have cross-drilled nuts/bolts to facilitate the fitting of wire seals. Should a competitor subsequently wish to change or repair an engine or component thereof, which will necessitate the breaking of a seal or removing any identification, this may only be done under the supervision of the Scrutineers. Once the change of engine or component is complete, the engine or component will again be sealed or identified.
- The changed component or engine must be impounded by the scrutineers.

xx) **Outside assistance**

No driver may receive outside help from any person other than a marshal or race official on the track once the karts have left the pre-start grid for the start of a race. Drivers may, however, during the race, enter the pits by the proper method, weigh the kart, receive assistance in the pits and then re-join the race.

The only exceptions to the rule regarding assistance on the track are:

- Marshals may assist drivers who have come to a stop to place a kart off the circuit to avoid obstructing other competitors.
- The starting of engines or pushing of karts is only permitted by the driver concerned when it is deemed safe
 - Bambino competitors may receive outside assistance with the permission of the Clerk of the Course from a limited number of identified parents/pit crew who have been given an introductory marshalling course and are registered as Officials with visibility vests, and signed indemnities.
 - These Officials must assist any Bambino driver and not only their own children, otherwise they will no longer be permitted to assist on track

From the commencement of the official qualifying practice only authorized officials are allowed on the track. The penalty for receiving outside assistance, whether the assistance is solicited or not, unless it is an authorized race official, is automatic exclusion from that race or qualifying. ~~Where a circuit has provision for a demarcated area for repairs to karts which does not require karts to cross the scale, competitors may make use of this area DURING RACING ONLY without the necessity of first crossing the scale. The location of the said demarcated area must be made known to competitors at drivers briefing and karts entering this area for repairs must come to a complete standstill prior to returning to the race circuit.~~

xxi) **Fuel and oil**

Where the SR's for an event specify the fuel to be used: - the name of the filling station and pump number will be the only permissible fuel for the event in question. The organizers have the right to undertake fuel testing by using a digitron fuel meter. Only the specified brand of oil and at the specified ratios may be used and this may not be tampered with in any way. The Series promoters will nominate the oils prior to each SA National Championship event. These will be the only fuel oils permitted for the event. The fuel/oils so nominated and appearing in the SR's will be used for any fuel/oil changes ordered by the organisers. Also refer to article 23.15 Fuel Testing.

xxii) **Tyres**

The use of wet weather tyres in qualifying or any of the races will not be permitted unless a wet race or practice is declared by the Clerk of the Course. Likewise, the Clerk of the Course can withdraw authorization for wet weather tyres.

- New or used tyres can be used. The organisers must arrange for each competitor's tyres to be marked with his/her racing number and class when exiting the circuit after qualifying. The marked tyres and/or rims may be impounded by the organisers and re-issued on the day of the race if originally issued prior to race day.
- Both dry & wet weather tyres must be identified prior to being used. Checks on identified tyres may be made at any time throughout an event and any competitor found using any tyre, which has not been identified for the event will be excluded from the prior races or qualifying races. Exchanging of tyres between competitors is forbidden and the penalty will be the same as above.
- It is prohibited to use any chemical treatment, or other means, to artificially enhance the performance of tyres used during official practice or racing. The organisers reserve the right to replace one or more of any competitor's tyres, with a substitute tyre of similar wear, should they believe such action to be warranted. Should a tyre be worn to the extent that it is no longer safe for use, the organisers may require such a competitor to withdraw from further participation in the

event so affected.

- The only substance that may be used to inflate tyres is normal air (compressed or otherwise). Race organisers shall have the right to require competitors to deflate their tyres on request and re-inflate them under supervision using normal air. The use of any tyre inflation substance other than normal air and/or the failure to respond to a request to deflate/re-inflate tyres as above shall be deemed a contravention of the technical regulations and shall be dealt with accordingly.
- Tyres may not be deflated after the completion of qualifying or race until your kart has left Parc Ferme.

xxiii) **Variation of regulations**

Any variation of these regulations approved by MSA will be advised by means of issuing Versions of the Standing Supplementary Regulations or MSA bulletin for each event affected by such variation.

19. POINTS SCORING

- i) Where championship regulations refer to 'best scores' counting toward a championship, it is clarified that, any exclusion that the COC have deemed serious may NOT be dropped. The table of available scores is referred to in the relevant championship regulations. Competitors found guilty of an infringement, resulting in exclusion, will score zero (0) points
- ii) **Tie** - In the event of a tie having to be resolved to declare a winner, preference will be given to the competitor having the greatest number of first places. If a tie still remains, the greatest number of second places, failing this third places, and so on, will be taken into account. Should there still be a tie; the competitor having the highest score in the last race shall take preference. In the event of tied competitors not being classified in the last race, then the previous race's finishing order will be taken into account, and so on until the tie is resolved
- iii) For Club and Regional Events: - scoring is according to the relevant regulations governing the individual championships.

20. NATIONAL CHAMPIONSHIPS

- i) SA National Championship series of events shall be scored according to the specific series regulations.
- ii) **Mandatory circuit closure prior to National events may be imposed by the series organisers and this will be defined in the sporting regulations for the specific series.**
- iii) **National Championship Classes 2020**
National championship series shall be held for the following classes:
 - iv) **SARMC Series classes:** Bambino, Micro Max, Mini Max, Junior Max, Senior Max, Rotax DD2 and DD2 Masters.
 - v) **ROK CUP SA Series classes:** Kid RoK, Mini RoK, OKJ and KZ2, KZ, KZ Masters.
 - vi) A minimum of 10 starters per national championship class per event shall be required for a national champion to be declared in the class. Four events must be hosted in at least three MSA designated regions. The MSA Karting Commission reserves the right to review for the following year the national championship status of any class that fails to comply with the minimum requirements. Refer also Art. 10) i) Also refer to GCR 230 & 266
- iv) **All events will take place over a maximum of three days (including the half day open practice).**
Rok National Events will be held over 2 days, Friday and Saturday.
- vi) Race distance per National Championship race shall be prescribed by series regulations in line with:
Bambino Minimum 8km Maximum 10km
KID Rok - Minimum 8km & maximum 12km.
Micro Max, Mini Rok/Mini Max: - Minimum 10km & maximum 15km.
All other classes: - Minimum 15km & maximum 25km.

vii) **EVENT FORMAT**

Refer to Series sporting regulations

viii) **POINTS SCORING**

35, 32, 30, 29, 28 and so on. Non-finisher 5 points less than lowest placed finisher. Finisher = more than 67%

21. OBSERVATION FORM

COMPLETION OF THIS FORM WITHIN 30 MINUTES OF OBSERVING AN INCIDENT SERVES TO BRING AN ISSUE TO THE ATTENTION OF THE SENIOR RACE OFFICIALS AT AN EVENT. IT SHALL NOT REPLACE A FORMAL PROTEST AND THE RACE OFFICIALS SHALL NOT BE OBLIGED TO ACT ON ITS CONTENTS. FORMS WILL NOT BE ACCEPTED AFTER 30 MINUTES OF THE INCIDENT OCCURRING. ANY COMPETITOR WHO CONSIDERS HIMSELF/HERSELF SUFFICIENTLY AGGRIEVED, AND REQUIRES AN ISSUE TO BE FORMALLY INVESTIGATED, IS ADVISED TO RATHER LODGE A FORMAL PROTEST/APPEAL AS PER THE RELEVANT GCRs WITHIN THE STIPULATED TIME LIMITS.

22. PROTESTS

Refer to Part IX of the GCR's.

23. APPEALS

Refer to Part IX of the GCR's. Where a formal appeal (following a protest) arises as the result of exclusion in terms of a contravention of the technical regulations and specifications, the part/s under dispute will be impounded by the relevant officials, sealed and submitted to MSA Head Office. Should notice of intention to appeal not have been timeously lodged in terms of the regulations, and the part/s are therefore not impounded, late acceptance of such appeal shall not be considered or granted. An appeal correctly lodged in terms of the above will be considered by an MSA Court of Appeal, the members of which shall include at least TWO members of the MSA Karting Commission's Technical Committee and the event TC.

24. KARTING SPECIFICATIONS – GENERAL

All Karts are to be raced as supplied, other than as listed below or as stated below for clarification where necessary. In the event of anything not be covered either in the published homologation documents which are available on the MSA web-site, then the general chassis specifications as they appear on the CIK web-site will apply. This is applicable to ALL chassis including those 750mm to 950mm chassis homologated by the Italian ASN or by Motorsport South Africa.

Detail references can be found on the CIK website and should be used only when not referenced in these regulations.

24.1 CHASSIS (only homologated chassis as per Art. (24) may be used)

- **Wheelbase:**

- **CIK and Rotax homologated chassis:**

- The minimum shall be 104cm, maximum 105cm (+/- the allowance as per the specific chassis homologation).

- **Mini Rok, Mini Max and Micro Max**

- Shall be 95.5cm (+/- the allowance on the approving ASN homologation documents)

- **Bambino class**

- Shall be 77cm (+/- 10mm)

- All measurements shall be taken between the centers of the front and back axles.

- **KID Rok**

- May use either a 89.5cm or 95.5cm chassis (+/- the allowance as per the specific chassis homologation).

- **TRACK**

- Minimum of two thirds of the wheelbase measured to the outermost face of the tyre or rim, whichever is the greater. The maximum overall width is 140cm, except for Bambino, Micro Max and Mini Max the maximum width is 115cm. Mini Rok and KID ROK classes, which is 110cm is measured to the outermost face of the rims or tyres, whichever is the greater.

- **HEIGHT**

- A maximum height of 60cm from ground level inclusive of bodywork is allowed.

- **FRAME**

- All main chassis components must be firmly bolted or otherwise secured to the frame

- **BODYWORK – GENERAL**

- **All body work must be CIK approved and be raced as supplied as per CIK Homologation. All side pod and nose cone mounting bars must display the CIK homologation number.**

- CIK homologated rear bumpers (Senior chassis).MSA, Rotax DD2 and ACI/FIK approved Rear bumper (protection) must be used and may only be mounted with the fixing method as supplied by the chassis manufacturer, mixing and matching of fixing bracket or components between chassis brands is forbidden.

- Nose cones may NOT have additional fastenings or securing for example, plastic zip ties, In the interest of safety, it is permitted to secure the nose cone clamps with a single loose cable tie as pictured below to the upper bumper bar.



- No part of the bodywork may be used as a fuel tank or be used to carry ballast.
- **Front bumper** – Shall comply with the CIK or manufacturers specification (in the case of ASN homologations)
- **Front Nose Cone** – The front fairing (nose cone), using the front fairing CIK mounting kit must always be correctly installed

and in the correct position during the competition.

- **Front Nose Cone** – May not be repaired and must be replaced if it has holes other than the standard manufactured holes
- **Rear Bumper** -In the case of the Bambino and classes using the 89.5 and 95cm chassis, all rear bumpers and protection shall be similar to the CIK type.

SAFETY:

Race recording devices: eg. Go-Pro HIGHLY RECOMMENDED

Recording devices (Go-Pro's) may only be mounted with the standard brackets (as supplied with the unit) to the kart's plastic side pods, front and rear bumper or bib and on top of the radiator. No additional mounting extension between the kart and the recording device is permitted.

A maximum of two recording devices is allowed per kart. **It is NOT permitted to mount any device on the helmet.**

On the grounds of safety, no hole may be bored in the frame, steering assembly (excluding those bored by the manufacturer in the steering wheel), seat supports or bumpers, or any other modification to the chassis and its' components for the purpose of lightening, or for any other reason other than required for normal fixing. The threads of bolts or studs fitted with "Nyloc" type nuts must protrude fully through the nuts. Including: -
Brake pedal to chassis. Brake rods (both ends). The master cylinder to the chassis. Brake calliper to chassis spindle (Shifters ONLY). Brake callipers to spindle. Brake disc to the brake hub. Weights **MUST** be double bolted. The steering column to the chassis. Steering wheel hub. Steering wheel hub to steering column. Tie rods at both ends.

FLOORING

There must be a floor made from aluminum sheet and/or resin cloth structure (carbon-fibre and Kevlar not permitted) that stretches from the front of the seat to the front chassis member of the kart. It must be edged on each side by a tube or a rim to prevent the driver's feet from sliding off the floor. The floor tray shall be basically of flat construction and shall not, together with any other part of the bodywork, resemble a skirt. No lightening holes, other than those made by the manufacturer may be cut into the floor tray, except that one hole may be drilled in the floor tray to accommodate the timing system pickup. No extension of the above specified floor tray either forwards or rearwards will be allowed.

24.2 WHEELS, RIMS AND TYRES

Refer to series sporting Regulations

24.3 BRAKES:

Carbon brake discs are forbidden. It is mandatory that brake discs are made of steel, stainless steel or cast iron.

All brake systems must be CIK/ASN homologated.

It is permissible to use the complete system (master cylinder, Calliper and brake pads) from one manufacturer on a different chassis.

- Bambino Class: Brakes must be effective and operated by foot pedal mechanically on both rear wheels simultaneously
- Micro Max, Mini Max, Kld Rok, and Mini Rok classes: Brakes must be effective and operated by foot pedal either mechanically or hydraulically on both rear wheels simultaneously.
- Junior Max, Senior Max and, Master Max, OKJ, and Super Rok classes: Brakes must be effective and operated by foot pedal hydraulically on both rear wheels simultaneously and be CIK Homologated. Front brakes are not permitted on any fixed gear karts.
- 6-speed gearbox classes KZ2 and Rotax DD2 must be fitted with hydraulically operated brakes effective on all four wheels simultaneously, but with independent systems front and rear so that in the event of one system failing the other will operate on either two front or two rear wheels and be CIK Homologated.
- Brake Pads & Discs: - taking into account wear and tear on the brake pad backing plates and the friction on the brake discs, these do not have to display the CIK numbers and logos but need to be compliant with the homologation specifications in all other respects.
- It is NOT permitted to 'mix and match' brake discs or any part of the brake system. It is however permitted to replace an entire brake system with a brake system of another manufacturer, provided the brake system is homologated by the CIK (or ASN, where applicable) and is approved in the South African homologation list.

24.4 STEERING

Any device mounted on the steering wheel must not protrude by more than 30mm from the plane forward of the steering wheel and must not have sharp edges.

24.5 TRANSMISSION

The drive of the transmission shall always be to the rear wheels. The ratios (engine and axle sprockets) are free, except for classes Bambino, KID Rok, Micro Max, Mini Rok and Mini Max and these ratios are specified in the specific series regulations. Except for Bambino, the aforementioned classes, the shaft (axle) must have a maximum external diameter of 30mm and a minimum wall thickness of 4.9mm at all points except the key housings. The length is 960mm +/- 10mm and weight 2900g +/- 100g. The rear shaft used on the chassis does not have to come from the same manufacturer as the chassis itself.

24.6 SEAT

The kart seat must be rigidly located on the chassis. It must be so designed so that the driver is securely located to resist movement when cornering or braking and shall not be cracked or damaged in such a way as to pinch, lacerate, be insecure, not provide the driver with adequate protection, or endanger a driver in any way. Seats supports MUST be mounted by using nuts, bolts, and a metal or aluminium washer with a minimum diameter of 35 mm and 1,0 mm thickness to eliminate seat supports break through. The lower seat bolts may be loosened in the event of rain.

24.7 CHAINGUARD

A chain guard is compulsory and must be an effective protection over the top and both sides of the exposed chain and sprocket and extend at least to the lower plane of the rear axledown a line at least level with the center of both front and rear sprockets.

Club status competitors are exempt from new fully enclosed chain guard, provided the scrutineer is satisfied that the chain guard being used serves the purpose and is in good condition.

24.8 PEDALS

Whatever the position of the pedals, they must not protrude forward of the chassis, including the front bumper. Neither pedals may protrude forward of the chassis (including the bumpers) and MUST be mounted in front of the master cylinder. Brake pedal MUST have a double linkage to the master cylinder. Accelerator pedal MUST be equipped with a return spring. Pedal Extenders and Footrest are allowed.

24.9 ACCELERATOR

Pedal operated and equipped with a return spring to close the throttle when released.

24.10 EXHAUST

So designed that exhaust gasses are carried away from and to the rear of the driver. The exterior of exhausts may be polished, except in the Rotax classes where this is not permitted. For all classes, no part of the silencer or exhaust pipe shall protrude beyond the chassis of the kart or bumpers and sideways beyond the line drawn between the outer edges of the front and rear tyres.

24.11 FUEL TANK

Fuel tanks must be firmly and adequately fixed to the chassis or the flooring and not by a temporary system of attachment. It must be constructed in such a way, that neither it nor the fuel pipes, which must be flexible, present any danger of leakage during a competition. Pressurized tanks are prohibited

Except for the Cadet class, it is mandatory to place the fuel tank between the main tubes of the chassis frame, ahead of the seat and behind the rotation axis of the front wheels.

The maximum tank capacity of the kart shall not exceed 10 litres.

For National Championship and Regional Championship events, fuel tanks must be readily removable (i.e. able to be removed within five minutes) and for this purpose it is required that the latest type removable tanks are fitted

All Fuel pipe to have spring clips/hose clamp/cable ties to prevent them coming off.

24.12 ENGINES

Refer to Rotax or Rok Series for specific technical and sporting regulations

24.13 RADIATORS

For those classes permitted to use water-cooled engines the radiator must not be placed in front of the pedals or behind the rear bumper. All the hoses must be of a material designed to withstand heat and pressure, and must be secured by clips/hose clamps of a suitable strength to withstand rough usage. Overflow catch tanks are obligatory. Where duct tape (or similar) is used to blank off the radiator, or part thereof, this must be fitted in such a way that it cannot be removed while the kart is on track. The use of anti-freeze is permitted in all events, notwithstanding anything that may be stated to the contrary in the international regulations for the class concerned.

24.14 Minimum MASS

The mass prescribed in **the specific series sporting regulations** shall always be deemed as being the minimum, including during qualifying, and will include the mass of the driver equipped for racing with helmet, visor or goggles, shoes, gloves

and protective clothing. Any ballast carried in order to meet the minimum mass prescribed must be firmly fixed to the chassis or seat to the satisfaction of the scrutineers. For any ballast weight greater than 2kg, attachment must be by a minimum of two M6 bolts or permanent fixings, with an additional bolt or fixing for every 4kg or part thereof.

24.15 FUEL TESTING

The following test method will apply to all karting events and classes as approved by MSA, Club, Regional and Nationals. The Test instrument will be the Digatron FT64 which must be clearly identified by a serial number or identifying mark and will be the only instrument of the day to be used. Only MSA approved Fuel TC's may perform fuel testing.

The only calibration on the instrument of the day will be the reading from the mixed reference sample fuel that is kept by the fuel TC.

A clearly marked reference sample of every mix ratio (fuel: oil) will be kept by the fuel TC or COC.

The difference in reading between the reference sample that is applicable for each class and competitor fuel reading may not be more or less than 2, this value may be changed by the Fuel TC of the event before qualifying. Fuel testing can be done at any time during the event.

The temp difference may not be more than 2 degrees Fahrenheit. If the temperature is not within the limits, the fuel tank of the competitor must be impounded and sealed, the competitors fuel temperature will be allowed to equalize to the reference sample and a new reading obtained no later than 30 minutes before publication of final results.

The minimum amount of fuel in the tank at any time may not be less than 300ml, the fuel may be decanted into a suitable container for the necessary testing to be done.

It is the responsibility of the competitor to be present at all times when readings of the fuel are done and to check with the fuel TC that the fuel used by competitor is within the set parameters.

The COC or Fuel TC may at any time have competitors fuel replaced with organisers fuel.

A penalty of exclusion will apply for any infringements of the above and is not protestable, and repeat offenders will have their race licence revoked.

24.16 TITANIUM

The use of titanium for any part of a kart is forbidden.

24.17 BATTERY

Starter batteries must be firmly, and safety secured to the main left rail of the chassis.

25. HOMOLOGATION

Homologation is the identification of equipment or materials used for the purpose of competition in kart racing. It is an official certification made by MSA that a chassis or engine or type of specifically designed equipment has been made and is freely available in sufficient numbers to justify being sanctioned for racing in one or more class. Classes are classified either restricted (where only one or two make/models of engine and/or chassis are permitted) or unrestricted. Where classes are restricted to one or two chassis or engine makes/models or one make/compound of tyre, MSA may impose a maximum retail selling price for this equipment (including spares) based on the prices, increases and exchange rates submitted by accredited dealers when making application for homologation of this equipment.

26. CHASSIS AND ENGINES

Applications for homologation of engines, chassis, etc. to be used in any class, regardless of the status of that class will only be accepted from MSA-accredited importers and karting dealers. There is no predetermined expiry date for the homologation of the various engines. The MSA Karting Commission shall be entitled to terminate the existing homologation of any engine or chassis with a minimum of one calendar year's advance notice to competitors. The MSA Karting Commission shall have the right to invite new applications for engine and chassis homologation at any time. Each homologation period is valid for a three-year period unless otherwise specifically stated. Chassis identification for homologation purposes is by either its CIK homologation document or under a similar MSA homologation document number where no CIK document existed at the time of original MSA homologation. NOTE: Applications for the homologation period will only be considered for chassis having CIK homologation or locally manufactured chassis/brands to be homologated through MSA, or another ASN in the case of chassis for use by competitors under the age of 13 or having Rotax approval in the case of the DD2 class.

Once an engine has been homologated for a class then any changes during that homologation period, be they upgrades, or replacements are only allowed, provided they fit into the norms and standards for that class and provided they conform

to any new International Technical Specifications issued by the manufacturer. A notice period of 90 days may be given to competitors before implementation. Single engine classes must remain exactly that – one engine make formulas. The standard 3-year homologation cycle continues in all other regards.

HOMOLOGATION OF LOCALLY MANUFACTURED CHASSIS

The following requirements must be met:

- i. Produce 10 identical complete chassis of the same model, plus 5 complete chassis for Spares.
- ii. Brake system to be CIK approved
- iii. Bodywork must be CIK approved
- iv. All chassis models to have specification drawings as per CIK regulations
- v. Any changes in design during the homologation period must be within CIK permitted rules
- vi. All chassis must be clearly marked with a homologation plate that conforms to the CIK rules
- vii. One sample of the tubing must be sealed and retained by MSA for the duration of the homologation period
- viii. All rims to be CIK approved

HOMOLOGATION PROCEDURE

i) Engines: -

- Applications for extensions / renewal of homologations for engines must be made no later than 31st May of the year preceding each new homologation period. All applications to be made in writing to MSA Karting Commission whose Homologation and/or Technical Committee will vet and process these applications and submit their recommendations to the MSA Karting Commission for their endorsement at their mid- year commission meeting of the same year. Their decision will be final. Where homologation applications are refused, the applicable application fee will be refunded. Renewal fees: -For extension of an existing homologation for an engine make/model for all classes, the fee is R3000.00 (excl. VAT) per make/model per class payable on application. No inspection is required.
- For new engine makes/models not presently homologated for any class a fee of R3000.00 (excl. VAT) per model per class payable on application and must be submitted for consideration by no later than the 31st of March of the year preceding the intended implementation date. Final approval of homologation will normally only be granted subject to the inspection of 5 units plus adequate spares and the payment of any inspection costs.

ii) Chassis: -

A three (3) year moratorium on new chassis Brand registration will be placed after 31 March 2020 and will be in effect to 31 December 2023.

No new chassis brands will be homologated for use before the 1st of January 2024.

For extensions/renewals of CIK/locally/other ASN homologated models of an existing homologated chassis brand for all classes, the fee is R5850.00 (excl. VAT) per brand.

- All existing brand renewal will need to provide proof of minimum 5 new chassis imported per annum, 1 January to 31 December for each year during the homologation cycle. For a new brand homologation this will be applicable from year 2 and 3. If the requirement is not met, the Brand and chassis approval will be withdrawn and competitors will be allowed to race under private homologation for minimum of one year.
- MSA reserves the right to extend the homologation of any specific model (CIK or non-CIK) chassis previously homologated, in the absence of an application from an accredited dealer.
- Subject to the 3-year moratorium, chassis brands not presently homologated (New Applications) only CIK/locally homologated models permitted. Applications may be received at any time, but not later than the 31st of August of the year preceding the year from which the chassis is intended for use and must include a letter of appointment by the chassis manufacturer as the South African distributor. The application fee is R5850.00 (excl. VAT) per brand is payable on application. Final approval of homologation will only be granted subject to the inspection of 25 complete CIK homologated chassis and the payment of an inspection fee of R5850.00 (excl. VAT) plus any inspection costs. Final approval, after inspection will attract an approval fee of R5850.00 (excl. VAT) per brand. Successful applications must have received final approval after inspection by no later than the 31 March of the following year. Failure to have final approval by that date will automatically cancel the application.

Once homologation of the brand is finally approved following the inspection of the 25 CIK units, the applicant may homologate the same brand Mini and or Rotax DD2 chassis, subject only to inspection fees and any related costs, provided same is approved by another ASN or Rotax in the case of the DD2 chassis.

- All BRAND homologations will be linked to a MSA approved CIK/FIA homologation number, if a new chassis is homologated for a brand in the 3-year cycle all relevant information must be presented to MSA for approval, equipment may only be raced after MSA approval.

- All chassis entered and raced must be presented as the approved brand for the chassis homologated, it may not in any form or guise appear or be presented as any Non MSA approved brand.

- **Bambino, Micro and Mini Classes**

For new chassis (Subject to the 3-year moratorium) and engines not presently homologated for the Bambino, Kid Rok, Micro, or Mini Max Classes in such cases, one example of an engine or chassis must be submitted for inspection together with a list of retail prices plus increases for the period of homologation for the complete engine or chassis as well as all spare parts. In addition, all technical specifications and drawings must be submitted. If acceptance of the application is granted, final homologation will only be granted once a total of 15 engine units plus adequate spares has been made available for inspection (including the original). The fee is R3000.00 (excl. VAT) plus inspection costs upon inspection for engines. For chassis, the brand of the CIK homologated chassis must be homologated before these classes can be homologated.

iii) Summary of Homologation fees, per three (3) year cycle or portion thereof.

Tyres: -

Homologation Application Fees:	R3000.00 excl vat per brand and compound
Homologation Testing Fees:	R3000.00 excl vat per brand and compound
Homologation Approval Fee:	R3000.00 excl vat per brand/compound plus R3000.00 excl VAT per class
Homologation Renewal Fees:	R3000.00 excl vat per class.

Engines: -

Homologation Application Fee:	R3000.00 excl vat
Homologation Inspection Fee:	R3000.00 excl vat, per make / model, plus expenses
Homologation Approval Fee:	R3000.00 excl vat per class
Homologation Renewal Fee:	R3000.00 excl vat per class

Chassis:-

Homologation Application	R5800.00 excl vat per brand
Homologation Inspection	R5800.00 excl vat per brand, plus inspection costs
Homologation Approval	R5800.00 excl vat, per brand
Homologation Renewal	R5800.00 excl vat, per brand

iv) **HOMOLOGATION FOR PRIVATEERS**

In the event of no accredited dealer making an application to extend the homologation of an engine/or chassis homologated for the previous period nor MSA extending its homologation, an application may be made by a competitor, provided the owner can satisfy MSA Karting Commission that the chassis or engine was in South Africa prior to the expiry date of the previous homologation period. In these circumstances the authorization of homologation is restricted to that particular numbered chassis/engine of the named owner. In such instances a fee will not be levied. Chassis or engines homologated by privateers for preceding homologation periods in terms of previous regulations may be extended as well in terms of these regulations.

v. **TYRES**

The homologation period for racing kart tyres is 3 (three) years and MSA accredited dealers are

invited to offer suitable make/compound of slick and wet weather tyres (to be the same make) for each racing class. Where the tyre being offered is of a different make/compound to the one presently being used by such class, two complete sets are to be supplied free of charge for evaluation purposes. The intended retail-selling price plus increases applicable for the homologation period are to be submitted. The application procedure and dates will be the same as applied for engines and chassis. The homologation application fee is R3000.00 (excl. VAT) per make/compound, plus testing fees and approval fees per class.

GENERAL

The MSA Karting Commission reserves the right at any time to homologate kart racing equipment and wearing apparel outside of what is specified in these regulations. In such instances, MSA Karting Commission will, at the time, determine the homologation fee, inspection costs and the period of homologation. MSA Karting Commission reserves the right, without obligation to any accredited dealer or individual MSA licence holder, to determine, modify or extend any homologation period at any time by notification in writing to that effect, as from the date stated in the said notification. Furthermore, the MSA Karting Commission is not bound to assign any reason whatsoever for any decisions in connection with homologation of racing kart equipment and wearing apparel.

vi **HOMOLOGATED CHASSIS BRANDS FROM 01/01/2020 to 31/12/2023**

Chassis for use in the Bambino Kid Rok, Micro Max, Mini Rok and Mini Max classes must be homologated by the CIK (or an ASN elsewhere in the world) or MSA.

Chassis for Junior Rok, Junior Max, Senior Rok, Senior Max, Master Max and the -KZ2 ,KZ & KZ Masters classes must be CIK homologated. Chassis for use in the DD2 class must be homologated for use by ROTAX

The following are the only chassis brands approved for use for the period 1 January 2020 to the 31 December 2023

<u>50cc Cadet Class</u>	<u>KID Rok, Micro Max, Mini Rok and Mini Max</u>	<u>125cc CIK Homologated Chassis</u>	<u>DD2 Class</u>
	Parolin	Parolin	Parolin
	FA	FA	FA
	Birel & Birel Art	Birel & Birel Art	Birel & Birel Art
	CRG	CRG	CRG
	Energy Kart	Energy Kart	Energy Kart
	Exprit	Exprit	Exprit
	Formula K	Formula K	Formula K
	Haase	Haase	Haase
	Intrepid	Intrepid	Intrepid
	Kosmic	Kosmic	Kosmic
	Praga	Praga	Praga
	Riccardo	Riccardo	Riccardo
	Tony Kart	Tony Kart	Tony Kart
Top Kart	Top Kart	Top Kart	Top Kart

Chassis which do not appear on the above list will NOT be permitted to participate in any club, regional or national event, unless privately homologated in terms of ART 25 iv)

vii) **HOMOLOGATED ENGINES FOR 2017 – 2020**

Engines which do not appear on the below list will NOT be permitted to participate in any club, regional or national event until homologated.

ROTAX CLASSES

- **Bambino-Class**
Comer Model C50 engine complying with the current MSA Karting Commission Specification Sheet published on MSA website and www.kart.co.za
- **Rotax Classes**
125 MICRO MAX and MINI MAX
125 ROTAX complying with the Rotax Max Challenge Technical Regulations as well as SARMC supplementary technical regulations for 2019
- **125 JUNIOR MAX**
125 Junior MAX complying with the Rotax Technical Specifications.
- **ROTAX Senior MAX Class**
ROTAX 125 MAX complying with the Rotax Max Challenge Technical Regulations
- **MASTER MAX CLASS**
ROTAX MAX complying with the Rotax Max Challenge Technical for Senior Max
- **ROTAX DD2**
ROTAX 125 DD2 complying with the Rotax Max Challenge Technical Regulations
- **Rotax DD2 Masters Class**
ROTAX 125 MAX DD2 complying with the Rotax Max Challenge Technical Regulations

ROK CLASSES

- **KID ROK & MINI ROK Class**
As per the technical information which can be found on the MSA Website www.motorsport.co.za

- **OKJ**
Vortex direct drive DDJ engine. Technical Specification on request from MSA as submitted part of homologation.
- **Super ROK**
Vortex direct drive DVS engine. Technical Specification on request from MSA as submitted part of homologation.
- **KZ2, KZ , KZ Masters Classes**
Refer to 2020 Regulations and Specifications for the National KZ2 and Interprovincial KZ Shifter classes.

PROCEDURES TO INTRODUCE A NEW CLASS

An accredited importer wishing to have a new class considered must: -

- Obtain a letter from clubs in each Region confirming that said clubs are willing to have the proposed new class demonstrated.
- The importer will own 5 units, which units may only be demonstrated and may not be sold.
- Once demonstrations at Clubs in each Region with at least 5 karts is successful and after receipt of competitor feedback and snags list (if any) and a survey of competitors to be shared with the Clubs in each Region where the demonstrations took place has been completed, with not less than Four clubs in Three regions supporting same, then: -
- The importer may apply for homologation of the class for use at club level only; once this has been approved the importer may proceed to sell engines.
- Competitors buying into this class (s) must sign a disclaimer that MSA is not under any obligation to elevate said class(s) beyond club status, nor responsible for the success or lack thereof even at club level.
- Based on interest and volume a regional committee may consider regional status after two (2) completed and successful years at club level.
- The standard three (3) year homologation renewal cycle will apply thereafter.

vi) ACCREDITED IMPORTERS

- A register of accredited karting equipment importers will be kept by MSA Karting Commission.
- By applying for registration, importers will undertake that all new equipment sold will comply with MSA Karting regulations in respect thereof and that all goods will be available within any price limit stipulated in MSA Karting regulations, MSA circulars or confirmed letters of agreement in respect of chassis, engines and tyres for restricted classes. This clause does not diminish the responsibility and ultimate accountability of the entrant/competitor to ensure that this equipment complies with the relevant rules, regulations and technical specifications.
- Failure to respect the undertaking in (ii) above will result in the importer concerned being liable for the warranty replacement of parts and labour. In the event of repeated failure on the part of the dealer to respect this clause, accreditation may be withdrawn.
- An annual renewal fee of R3000.00 (excl. VAT) is payable on application for renewal.
- Upon registration the MSA Karting Commission will:
- Publish the names of accredited importers and local manufacturers of homologated equipment in the annual MSA Karting Handbook.
- Provide a copy of the MSA Handbook.
- Ensure all dealers are on the MSA mailing list, which will include receiving information circulars, which are issued from time to time by the CIK.
- Extend invitations to any consultative meeting held by MSA Karting Commission as may be deemed necessary.
- Ensure free access to kart circuits by means of an MSA Accreditation Card.

27. SA ACCREDITED KART IMPORTERS LIST

COMPANY	ADDRESS	CONTACT NO'S
BENONI SPORT & BUSINESS PARK (PTY) LTD Official Importers and Distributors of Formula-K Products. Official Importers and Distributors of TM Engines Distributors of Kart Accessories and Spares	29 Golden Drive Morehill, Benoni P.O. Box 13505 Northmead	Fabienne Lanz Cell: 079 525 8772 Email: fabienneracing@hotmail.com Phillip Swanepoel Tel: Cell: 082 777 8368 Fax: 011 425 1670 info@formula-k.co.za

<p>ED MURRAY RACING CC Promotors of the SA ROTAX Max Challenge National Karting Series. Southern African Distributor of : ROTAX Kart Racing products, Mojo tires, CRG and Top Kart Chassis, Bambino 50cc Comer engines, AIM Mychron timing systems and other quality karting accessories.</p>	<p>Zwartkops International Kart Raceway R55, Pretoria West</p> <p>P.O. Box 70725 The Willows, 0041</p>	<p>Jennifer Verheul Tel: 087 551 1678 (012) 384 2303 Cell: 082 294 7485 Fax: (086) 509 4670 Email:info@kart.co.za Website: www.kart.co.za</p>
<p>EMR KARTSPORT (Pty) Ltd Authorised ROTAX Service Centre. Mojo tyres, CRG Chassis, Comer Top Bambino engines, AIM Mychron timing and other brands of chassis. Storage, engine building, setup and repairs.</p>	<p>Killarney Raceway Potsdam Road Cape Town</p> <p>PO Box 70725 The Willows 0041</p>	<p>Tel: (021) 556 1347 Cell: 083 662 1177 Email: info@kartsport.co.za Web:www.kartsport.co.za</p>
<p>SPICE KARTING Importers and suppliers of PRAGA karts and spare parts</p>	<p>8 Basson Avenue Bassonia Gauteng</p>	<p>Tumi Mailula 082 579 3312 tumi@mbconsultants.co.za</p>
<p>RALPH ODENDAAL RACING t/a Punjabi Kart Parts Importers of Intrepid Chassis, Engine Hire and accredited Rotax and Maxterino service centre. Track side assistance and driver training. Kart storage & suppliers of race apparel</p>	<p>38 Beare Drive Padfield Park Pinetown 3610</p>	<p>Ralph Odendaal Cell: 076 817 5287 Email: intrepidkartsa@gmail.com</p>
<p>RKT Importers & Distributors of TonyKart, Kosmic Kart and Exprit. Importers & Distributors of: MIR, FreeM, Unipro, Greyhound seats & CZ Chains.</p> <p>VORTEX ROK: Importers & Distributors of Vortex Rok engine products and spares; Kid Rok, Mini Rok, OKJ Academy and Super Rok engines Visit www.rkt.co.za or contact us on 016 421 4274. For ROK Information please visit www.rokcup.co.za</p>	<p>RKT HQ 38 Kariba Str Powerville Vereeniging RKT@Zwartkops Shed 10 Zwartkops Intl Raceway</p>	<p>Etienne Roos Tel: (016) 421 4274 Cell: 082 6000 180 Fax: (016) 421 2509 Email:Etienne@rkt.co.za Website: www.rkt.co.za</p>

<p>RICCIARDO KART SA Importers & Distributor of BIRELART karts , RICCIARDO karts and FREELINE spares. Authorised supplier and service centre of ROTAX products. Kart preparation, Racekart rentals for the rotax racing series. Arrive and Drive packages. "</p>	<p>69 O'reilly Merry Street Rynfield Benoni 1518</p>	<p>Neil Smith Tel: 011 849 8495 Cell: 0828862444 Email: sales@ricciardokart.co.za www.ricciardokart.co.za facebook; @ricciardokartsa</p>
<p>SWIFT RACING Importer of Energy chassis, spare parts and racewear. Importer of IAME and Parilla engines. Importer of Stilo helmets, Stand 21 racewear and helmets. Alfano timing equipment and greyhound seats.</p>	<p>36 Bukes Street P.O. Box 856 Bothaville 9660</p>	<p>Flip Viljoen Cell: 073 133 7750 Email: Viljoen.flip@gmail.com Philip Viljoen Cell: 079 515 6203</p>
<p>I-CUBED DISTRIBUTION (PTY) LTD T/A iCubed Africa Importer of Parolin chassis and spare parts.</p>	<p>Suite 110, Cotswold House, Greenacres Office Park, Barry Hertzog, Rustenburg and Victory Road. Victory Park 2195</p>	<p>Brandon Whiteley Cell: 081 497 9788 Email: info@icubedcapital.co.za Imraan Kajee Tel: 011 888 0027 Cell: 072 414 5252 Email: imraan@icubedcapital.co.za</p>
<p>KORRIDAS Importers of HAASE Chassis</p>	<p>PO Box 75189 Garden View 2047</p>	<p>Paulo dos Santos Cell: 083 406 9356 Fax: 086 602 6379 Email: Paulo.dos.santos@oracle.com korridassouthafrica@gmail.co.za elite.seguranca@tv cabo.co.mz</p>
<p>SGM ENGINES Importer of SGM engines and spare parts</p>	<p>11 Ocean View Dr Everton 3625 Durban</p>	<p>Mauro Munari 082 440 6194 mlrtilles@mweb.co.za Scott Falconer 082 769 6120 scottf734@gmail.com</p>