

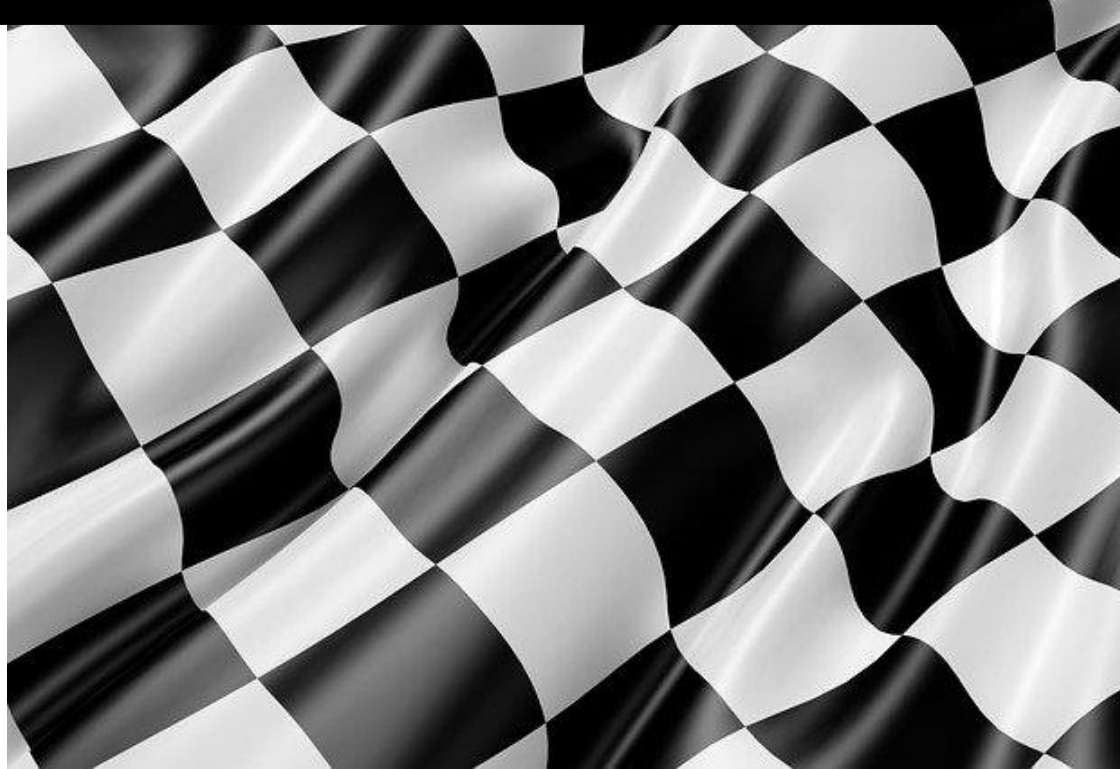

2022

MSA National Sporting Standing Supplementary Regulations

Formula 1600 Single Seater Championship



Version 1

1 January 2022

Ref: 162708



## REVIEW AND AMENDMENTS

Amendments and updates to the rules will be recorded in the Amendment Record, detailing the updated version, date of approval of the amendment and a short summary of the amendment.

## AMENDMENT RECORD

<i>Modified SSR / ART</i>	<i>Date applicable</i>	<i>Date of Publication</i>	<i>Clarifications</i>

## **1. REGULATIONS**

All races will be held under the General Competition Rules and Standing Supplementary Regulations of Motorsport South Africa (MSA), these regulations, event Supplementary Regulations and Final Instructions issued by the Promoters, as well as the applicable technical regulations for Investchem Formula 1600 National Championship series.

## **2. CONTROLLERS OF THE SERIES**

- a) MSA shall have overriding authority in all aspects of the series. Investchem Ford 1600 shall be responsible for the normal administration of the Formula Ford 1600 series, subject to the aforementioned.
- b) Investchem Formula 1600 will be responsible for the appointment of their committee, subject to MSA approval. This committee will manage Investchem Formula 1600 National Championship series.

## **3. ELIGIBILITY OF DRIVERS**

- a) All Entrants and Drivers must hold current National Competition licences issued by MSA.
- b) Competition licences will only be issued by MSA to fully paid up members of Investchem Formula 1600.
- c) Competitors who are of age 14 turning 15 years of age in the Championship year of Competition, may apply for their licences as per SSR1 of the Circuit Racing Regulations. Competitors who have either previously raced in a National Kart circuit racing Championship or other National Circuit Categories , or have sufficient other racing experience to the satisfaction of the Investchem Formula 1600 Committee , Driver Coach, TC and MSA Circuit Sporting Services Manager.
- d) Competitors with No Previous Racing Experience must apply for a Regional Licence and Compete in 2 x Regional Events prior to applying for a National Licence.
- e) No drivers will be eligible to compete unless they are fully paid up members of Investchem Formula 1600.
- f) Any driver wishing to make a once-off appearance in any of the race events must apply to Investchem Formula 1600's committee in writing for permission to race. Such permission may be withheld if, in the opinion of the committee, granting it is not in the interests of the series or motorsport in general.
- g) Any driver or entrant found guilty of having brought the series into disrepute (GCR 172) may have their membership with Investchem Formula 1600 suspended or even terminated by the committee, subject to the competitor's normal rights of appeal to MSA. (GCR 212)

## **4. AIM OF THE CHAMPIONSHIP**

To declare an SA National Formula 1600 Champion for 2022 (see SSR 82 i). The Champion also declared shall also be accorded the title of SA Drivers Champion

## **5. CHAMPIONSHIP FORMAT**

- a) The Controllers (Investchem Formula 1600) reserve the right to run a Race Format consisting of one, two or three races per race meeting with a minimum race distance of Ten Laps or 30 km per race.
- b) For reasons of force majeure or as agreed by the committees in consultation with the race organisers, a single longer race may be run, in which case double points shall be scored.
- c) There shall be one qualifying session at any scheduled race meeting. The qualifying session shall be of at least 15 minutes duration and shall determine the starting grids for the first and second race. The quickest lap time posted by each competitor will determine the starting order of Race 1 whilst the second quickest lap times posted will determine the starting order of Race 2. Should there be two or more competitors posting the exact time for qualifying, the "other" best time will be used to separate ties. (If a tie exists for Grid 1 – the second best time will be used to separate the tie. Similarly for Grid 2 – the Grid 1 times will be used to separate tie.
- d) In the Event of Series Hosting 3 x Races at an Event the Starting order will be Determined as per finishing order of Race 2 on the Day, However the top 8 x Finishers will start in Reverse order, ie; Race 2 winner will start Race 3 in 8th and 8th place finisher will start in 1st Place. 9th place finisher in Race 2 will start Race 3 in 9th place and so on.
  - d) Any driver not posting a lap time during Official Timed Qualifying will start Race 1 from the back of the class grid. Drivers not posting a time during qualifying will be given a starting position for Race 2 based on their finishing position in Race 1 but they will not start higher than 3<sup>rd</sup> on the grid, i.e. the front row will not be changed for Race 2. Should a driver only post one lap time in qualifying and therefore not have a time for the Race 2 grid, he/she will start Race 2 from the back of the class grid.
  - e) However should a competitor not partake/post a lap time in Official Timed Qualifying due to a valid reason.( Car not ready due to a Technical problem , Certified by TC and Clerk of the Course) , Then Competitor shall start both heats from the Pitlane

## 6. PRACTICE / TESTING

- a) At the discretion of the committee, practice/testing days may be authorised for the series.
- b) Competitors are allowed to Test at any National Race Circuit at any Time ( Testing Free of Restriction)
- c) Investchem Formula 1600 can arrange a Collective Test for All Competitors
- d) Formula Ford 1600 competitors may purchase additional Avon Tyres for Private Testing
- e) Any competitor that practices in a Formula Ford 1600 car prior to 1<sup>st</sup> Race Event or after the last championship event without written authorization from Investchem Formula 1600 shall be liable for a R10 000-00 fine payable to Investchem Formula 1600.

## 7. SCORING OF THE SERIES

- a) The champion will be the competitor with the greatest number of points scored as at the completion of the last race of the series.
- b) See SSR 82 (j) for the minimum number of starters required.
- c) In the Event of 3 x Races at an event, Points will be scored per Race

Points will be scored per class per race as follows

1st	10	<b>Pole Position: 1x Point (For Race 1 Only)</b>
2nd	8	<b>Fastest Race Lap of the Day: 1 x Point (Race 1,2 or</b>

3rd	6	<b>Race 3)</b>
4th	5	
5th	4	
6th	3	
7th	2	
8th	1	

- f) Where only one race of longer duration is run, then double the number of points listed above will be scored.
- d) In addition ONE Championship point will be scored for Pole Position for 1<sup>st</sup> Race only (Competitor that sets the fastest lap time in Official Timed Qualifying) and One Championship point will be scored for the Competitor who records the fastest race lap officially recorded in Race 1 or Race 2 of the day/event.
- e) Competitors will be allowed to Drop their worst TWO scores from a Race 1 or a Race 2, also if a competitor wishes **not to enter** an event for any reason whatsoever, then the competitor may also use these 2 races as dropped scores for race 1 and Race 2. **Exclusions may not count as Drop races . DNF** races can also be used as Points Drop races as the Competitor has entered the Event . There must be a minimum of 10 starters per class for at least 60% of the race meetings making up the series for a champion to be declared – refer SSR 82 (i).
- f) The Competitors 12/14 x Best scoring Races shall count towards the final championship standings.**(Including Exclusions)**  
  
7 x Events in Championship then 12 x Races points will count for Competitor 8 x Events in Championship then 14 x Races points will count for Competitor
- g) However should a Competitor wish to drop a score of their worst race and the Competitor set the Fastest Lap recorded in that particular Race, the competitor must then also drop the 1 x point scored for Fastest lap. Pole Position points are scored in Official Timed Qualifying and therefore will not be dropped, should the Competitor Drop Race 1 points.

## 9. Prize Fund

The following CASH prizes will be awarded for 2022 Formula 1600 Championship In accordance with GCR regulations

- a) **1<sup>st</sup> Place: R 200 000 – 00 Cash + Test in GTC Race Car**

**2<sup>nd</sup> Place: R 100 000 – 00 Cash**

**3<sup>rd</sup> Place: 50 000 – 00 Cash**

#### **10. SERIES EXPOSURE AND NUMBERS**

- a) Investchem Formula 1600 will issue each competitor with a competition number. Numbers complying with SSR 4 are to be displayed on the front and both sides of the car, as per the vehicle layout supplied by Investchem Formula 1600.
- b) Investchem Formula 1600 will issue competitors with a decal chart and decals, which must be strictly adhered to, failing which a competitor may not be permitted to start an event, or may be excluded from the results of an event (see also GCR's 246 and 247).

#### **11. ONE CAR PER RACE MEETING**

- a) For Investchem Formula 1600 Duratec other than in the case of clause 9 (b), each competitor may only qualify and race one identified car at each race meeting. No substitute cars (Spare Cars) will be allowed after the commencement of the official qualifying session.
- b) For Investchem Formula Ford Duratec 1600 should a vehicle be extensively damaged (body-work, or mechanical) beyond immediate repair during Qualifying or Race 1, the Technical Consultant together with the Clerk of the Course, may give permission for a substitute vehicle to be used. In this instance, the competitor will start from the back of the grid for Race 1 if the damage occurred during qualifying and from the back of the grid for Race 2 if the damage occurred during Race 1.

#### **12. TIMING TRANSPONDERS**

No competitor may take part in the practice sessions, qualifying session, warm-up or race without the official timing transponder mounted in the correct position in his/her vehicle.

#### **11. DRIVERS BRIEFING**

All drivers are required to attend the drivers briefing that is held at each event.

- a) Failure to attend will result in the offending competitor/s receiving a 5 grid place penalty for Race 1.
- b) Lateness will result in the offending competitor/s receiving a fine of up to R1000.00.

#### **13. DRIVER CONDUCT**

Refer to SSRs 45 to 66 (where applicable)

SAFETY CAR

DRIVERS ON THE COURSE RACING CONDUCT

OVERTAKING, RULE OF THE ROAD SAFE DRIVING

STOPS AT THE PITS

PUSH START FROM PITS

INCIDENTS, ACCIDENTS AND  
RETIREMENTS WITHDRAWAL FROM  
RACE (GCR 110)

PIT ATTENDANTS

- a) Drivers may only make one (1) change of direction between exiting one corner and approaching the next corner. Any further changes of direction will be regarded as 'weaving' and offenders will be penalised accordingly.
- b) Investchem Formula 1600 reserve the right to implement the so-called 'white line rule' outlined in SSR 50 (i) (i), selecting either one or two corners for this purpose. Drivers will be advised in advance where and when this rule will be enforced. In the event that the 'white line rule' is utilised, it shall not apply on the first and last laps of the race/s concerned.
- c) The provisions of SSR 50 i) h) are substituted with the following:

*If a car has left the circuit with all 4 wheels, it shall re-join the circuit at the nearest point to the exit from it, compatible with safety and without prejudicing a fellow competitor. Leaving the circuit (with*

*the resultant effect of missing a corner or skipping a chicane) and in so doing gaining an advantage by effecting an overtaking manoeuvre or preventing another competitor from overtaking, requires that the advantaged competitor will be compelled to allow the following vehicle to overtake him, so as to forfeit any advantage gained. This must be done within the next 2 corners, without any re-overtaking of the vehicle allowed through before a further corner has been taken. Failure by an advantaged competitor to forfeit the advantage gained as per the aforementioned shall render the offender liable to be penalised by the clerk of the course.*

**14. SAFETY EQUIPMENT AND APPAREL**

Individual competitors are responsible for ensuring their own safety during competition.

The following are specific requirements:

- a) Helmets (which must fit properly and be secured at all times) must be FIA-approved and incorporate a "HANS DEVICE" or "LEATT BRACE".
- b) Fire resistant clothing (minimum 2 layer overall, gloves, racing boots, socks, balaclavas and underwear), is compulsory. Such clothing should ideally be FIA-approved but suitable substitutes may be permitted at the discretion of the series controllers

**15. RACE NUMBERS**

Will be allocated by Investchem Formula 1600

**16. STARTING PROCEDURE**

Starts may either be standing starts as per SSR 38 or rolling starts as per SSR 39. Competitors shall be notified well in advance what form of starting procedure shall apply for a given race.

**17. PIT AREAS**

It is mandatory that all entrants and competitors pit in the area designated by the race

organisers.

#### **18. ELIGIBILITY OF VEHICLES – FORMULA FORD Duratec 1600 ONLY**

- a) The championship will be open to all cars complying with MSA specifications and Technical regulations for Formula Ford Duratec 1600 cars as per the 2022 MSA Handbook. Organisers may not accept any car that does not comply with these specifications and regulations
- b) All cars shall be fitted with the Standard Front wing and Rear wing as supplied by Investchem Formula 1600 for 2022 season , and Bodywork upgraded Sidepods and Front Nosecone + Crash Structure Front and Rear. NO MODIFICATIONS ARE ALLOWED TO THESE COMPONENTS.
- c) Bodywork Shape and Dimensions must be as Supplied from Investchem Formula 1600 Moulds ( NO ALTERATIONS ALLOWED)
- d) Additional Cooling Ducts may be fitted into Bodywork providing this does not Create any Aerodynamic Advantage. Any Modifications or Alterations must be Approved by the SASAA TC in Writing .
- e) Competitors may only use Investchem Formula 1600 supplied Controlled Engines for National Championship Official Practices + Official Timed Qualifying and Official National Championship Races.
- f) Competitors must use Investchem Formula 1600 Controlled Engines as Per Allocated to each Competitor by means of Engine draw or Investchem Formula 1600 Supplied Controlled Engines for National Championship Official Practice days and Official Race Events. NO OTHER ENGINES ALLOWED. ( As Per Investchem Formula 1600 Engine Contract)

#### **19. WINNERS ENGINE CLAIM – FORMULA FORD Duratec 1600 only**

Should a competitor be of the view that his/her engine is under-powered, he/she can claim the latest race winner's engine, subject to the following:

- i) The request shall be recorded in writing to Investchem Formula 1600 on the day of the race, together with a payment of R5000 to Investchem Formula 1600.
- ii) The engine shall be removed from the winner's car by his/her team immediately after the second race of the day.
- iii) The competitor claiming the equipment must return his/her existing equipment to the Investchem Formula 1600 immediately after completion of the final race of the day.
- iv) A fee of R2500 shall be payable to the owner of the claimed engine, by way of compensation.
- v) A fee of R2500 shall be payable to Investchem Formula 1600, to defray the cost of testing and compensate for time and effort spent.
- vi) Where a winner's engine has been claimed and he wins again at the next race meeting,  
  
his/her engine may not again be claimed, i.e. the same competitor's engine may not be claimed at two consecutive race meetings.
- vii) The competitor who claims a winner's engine may retain that engine for minimum of 2 x race events. Thus this competitor's engine may not be claimed by another competitor for 2 x race events.



- viii) Should two or more competitors claim the same winner's engine, the first claim received by the COC shall be the one accepted.
- ix) A competitor whose engine has been claimed shall receive a replacement engine from the F1600 SA's engine pool.

## 20. VEHICLE TECHNICAL SPECIFICATIONS

Detailed vehicle technical information for each class, which must be complied with at all times during race meetings, will be published separately by MSA.

## 21. MINIMUM WEIGHT

- a) Ballast can only be incorporated in the designated area.( In Cockpit area , Securley Fastened.
- b) The minimum weight of Investchem Formula Ford Duratec 1600 car as it crosses the finish line or at any time during an event must be 530 kg. (Note: The specified minimum weight is car + driver.)

## 22. TYRES

### Formula Ford Duratec 1600

Competitors will only use the AVON A29 specified slick tyres purchased from the

Single Seater Association and Specification as per 2022 Technical Regulations.

- a) A total of 5 x new set of tyres ( Set = 2 x Front + 2 x Rear tyres ) only, will be allowed for The National Championship of the 2022 season , 7 x Events.
- b) In the Event Race Organisers host a 8th Round in National Championship, Then the SASSA will amend Tyre rule accordingly
- c) 2 x Sets Tyres are allowed for Event 1 of 2022 National Championship
- d) 1 x Set Tyres ( Test) for Official Timed Practice( Friday) and 1 x Set Tyres( Race) used for Official Timed Qualifying and Heat 1 + Heat 2 of the event.
- e) New Tyre Events are only 1+3+5+7 ( 4 x Sets)
- f) Tyre Set 1 for 2022 will the only Set be used as Official Practice Tyres Registered for Event 1 +2 and for any other Official Timed Practice for events in 2022 Championship
- g) This set of marked tyres must be used for Official qualifying and Races 1 + 2 of the event. The Set of Tyres used in Event 1 Qualifying +2 x Races will be the only set of Tyres used in

Event 2 Qualifying + Races.( The set of tyres used at Event 1 will be same Tyres used at Event 2 unless otherwise Specified by TC or MSA Rule Amendment.

Scrubbing of tyres is not permitted.

- i. The set of marked tyres must be used in Official Timed Qualifying at Event 1 are the only set of Tyres to use in Race 1 + Race 2 at the 1<sup>st</sup> Event + 2<sup>nd</sup> Event of 2022.

Only marked tyres in the set from the supplier can be used.

- ii. Any marked tyres raced on at the previous events will be the only tyres permitted for use in the official practice sessions (as per event SR's) at the next event.
- iii. Should a competitor not have raced the previous event, then the tyres he/she will be permitted to use in practice at the next event shall be at the discretion of the Investchem Formula 1600 Committee and TC.
- iv. Tyre marking will only be done when the set of four tyres is produced for the weekend's racing at the stipulated time and place.
- g) Only 1 x set of Avon wet weather tyres will be allowed per event as registered with the Technical Consultant. Rain Tyres may be New or Used set.
- h) Any required safety-related tyre replacement will be at discretion of TC.
- i) Any deliberate flat-spotting of tyres will result in the TC selecting replacement tyres from used tyres available and presented to him.
- j) All tyre allocations will be car specific and identified (number designated).
- k) The use of tyre warmers is strictly forbidden.
- l) The use of any chemical treatment to new or used tyres is strictly forbidden.
- m) In the event of 3 x Races being held at an event, Then Tyres will be allocated at the Discretion of

Investchem Formula 1600 TC

- 

**Notes:**

- Once a new set of tyres has been recorded, It must be used at that event, and then it may be used at any time for Official Practice at Race events of the 2022 season.

The championship tyre registration of the allocated tyres for races will officially begin at the Official timed qualifying session (FRIDAY) for the first race of the 2022 National Championship season.

**Rain Tyres**

Competitors will be limited to the use of one set of specified AVON rain tyres per championship race meeting. Competitors will be required to nominate a set of rain tyres for a particular race meeting, which tyres will be marked by the technical consultant. This marked set of rain tyres will be the only set permitted to be used in the event of wet conditions at any time during the race meeting (official practice, qualifying and races).

**Notes:**

- Once a set of rain tyres has been recorded, at the event, the set of tyres may only be used at that event. These tyres may be used at next event or any other event providing they are registered with the TC for that event.

- The championship tyre registration of the allocated tyres for races will officially begin at the Friday Official Practice for the first Event of the championship season.
- Competitors who enter the series after the start of the season shall be issued tyres at the discretion of Investchem Formula 1600's Technical Consultant.
- **NB - All Investchem Formula 1600 competitors shall use the specified Avon rain tyres should a race be declared a 'wet race' by the Clerk of the Course at any given race meeting.**

Competitors may request a replacement tyre or tyres, where tyre/s have become unsafe for use due to bona fide accidental damage. This request must, in the first instance, be made to an Investchem Formula 1600 representative in writing within two hours after the end of the event in which the tyres were damaged. The onus is on the competitor to check the tyres on his car for damage after each event. Investchem Formula 1600 will examine the damaged tyre/s in question and, at its sole discretion, allow replacement tyre/s, which may be selected from any previously used set of tyres. New tyres will only be allowed in exceptional circumstances to be determined by Investchem Formula 1600.

**The use of tyre warmers is forbidden.**

**No mechanical (other than rubber removal by normal wear), heat or chemical treatments are permitted at any time to allocated control tyres.**

### **23. FUEL/LUBRICANTS**

- a) Should a fuel sponsor be secured, fuel shall be as supplied by the official fuel sponsor.
- b) On completion of any practice session, qualifying session or race there must be at least 3 litres of fuel capable of being drained from each competitor's car for testing purposes.
- c) Only 95 octane unleaded fuel is permitted (Pump Fuel) – No additives are permitted.
- d) The following procedure will be used to apply control fuel: Investchem Formula 1600 representatives / Clerk of Course (COC) will designate which cars are to run on a control fuel at any time before qualifying or a race. The competitors concerned will gather at a place designated by Investchem Formula 1600 no later than half an hour before the event. Competitors will then be required to drain all the fuel from their race cars. Competitors are required to provide all the necessary equipment to facilitate draining of fuel. The volume of the fuel to be drained must exceed fifteen litres. Competitors must provide containers to drain the fuel into. Control fuel will then be added to each car under supervision and the fuel filler cap and any pipes to or from the fuel tank will then be sealed. The onus is on the competitor to ensure that they obtain control fuel on time. Competitors should apply all the necessary safety procedures to ensure that the draining of fuel is undertaken in a safe manner. A fully charged and operable fire extinguisher of at least 2kg capacity is to be made available by each competitor during fuel draining and refilling at his/her vehicle.

### **24. DATA RECORDING**

It is each driver's responsibility to ensure that his/her engine and dashboard data is made available to the Investchem Formula 1600 technical support team directly after each practice session, qualifying session and race. Any deletion of data, or other failure to make it available, will result in offenders being moved to the back of the grid for the next race.

Investchem Formula 1600 competitors will make the recorded data available to the TC in order to check engine parameters.

## **25. TECHNICAL CONSULTANT**

- a) The appointed technical consultant will attend all events to ensure continuity regarding all technical aspects. The TC of a category may also appoint and include a deputy at an event.
- b) The TC or his deputy has the right at all times, in consultation with the COC, to refuse to allow any car considered to be un race worthy to participate in any practice session and/or qualifying session and/or race.

## **26. TECHNICAL INSPECTION**

- a) The TC, in conjunction and consultation with the COC, will carry out all post-qualifying and post-race technical inspections.
- b) The TC, in conjunction and consultation with the COC, may designate an area of pits for technical inspections to be carried out. He will be in control to police the area as per GCR 252.
- c) The TC, in conjunction and consultation with the COC may seal any vehicle or components thereof as per GCR 252 (vi) and remove them for specialised inspections. These inspections will be carried out under supervision of the COC and controlled by the TC.
- d) No travel expenses will be paid by the association to drivers/team owners in regard to any engine or part that is removed by the TC for inspection.
- e) Competitors may elect to utilize the services of a 3<sup>rd</sup> party at a post-race technical inspection. Investchem Formula 1600 will on request provide a competitor with an independent person who can be used as optional representation during this event. Should any irregularity be found during a strip it will immediately be suspended and all parts sealed and impounded. The competitor will be contacted and offered the opportunity to be present at the continuation of the strip at his/her own expense. Alternatively, the competitor may elect that the technical inspection continue with his/her appointed representative being present.

## **27. TECHNICAL PROTESTS**

Where a protest is lodged based on the technical regulations and specifications, the protestor must be prepared to submit his vehicle to the Technical Consultant for similar technical checks to those outlined in his/her protest to be carried out on his/her vehicle.

## **28. ECU REPLACEMENT**

The appointed Technical Consultant may, at any time during a race meeting (practice or racing), replace or exchange the ECU on any competitor's car, with an ECU of identical make + model. This is only if the TC believes that the competitor's ECU has been tampered with or damaged. The TC may at any given time during an event swap competitor's ECU with other competitors in order for a Fare comparison.

## **29. AMENDMENTS AND ALTERATIONS TO THE REGULATIONS**

The controllers reserve the rights to amend, alter or introduce additional regulations if deemed necessary during the course of the series. Any such amendment, alteration or additional regulation will only come into force once an official MSA bulletin/circular has been issued.

### **30. VEHICLE & COMPETITOR BRANDING**

Each participating vehicle shall display the relevant sponsor related branding on their race cars as indicated in the drawing supplied by Investchem Formula 1600.00

The racing overall of each driver is to be branded with the relevant sponsor related branding as indicated by Investchem Formula 1600.

With regards to The Sponsor's trademark badge on the drivers' overalls, the badge is to be positioned in the right-upper chest with dimensions of at least 120mm x40mm.

The Investchem Formula 1600 Chairperson, The Sponsor's and the television production house will be entitled to insist that drivers are correctly attired for television interviews and podium appearances.

### **31. INTERVIEW AND PRIZEGIVING BRANDING**

The Associations shall use their best endeavours to ensure that:

- a) All post-event interviews take place in front of a media backdrop which will include The Sponsor's branding.
- b) The winners' podium and prize giving events will use The Sponsor's branding.

### **32. MARKETING MATERIAL**

All official marketing material for the category will be branded as follows:

- a) The full name and/or logo of the Sponsors of the Super Series is to appear on (or be mentioned in or be displayed at) all promotional material and events including, but not limited to:

Posters	Press releases
Leaflets / brochures	Promotional Clothing
Podium branding material	Billboards
Letterheads	Timing and scoring sheets
Radio spots	Invitations
Track parades	Shopping centre promotions
Print advertising	

- b) All applications of The Sponsors of the Super Series logo are to be signed off by The Sponsor's before production / implementation thereof.

### **33. SPONSOR'S DECALS**

The Sponsor's decals will be supplied by Investchem Formula 1600 and are compulsory, as per the decal layout given.

### **34. COMPETITOR SPONSORS**

No competitor or team may agree to sponsorships from any brand that may be considered a competitor of The Extreme Tour Sponsor, or any of the category sponsors, without prior written approval from Investchem Formula 1600.

### **35. JUDICIAL CAMERA OPERATION PROCEDURES**

#### **Formula Ford Duratec 1600**

All cars must be fitted with an Investchem Formula 1600 supplied Go – Pro issued camera at each race event. All cameras, mountings and memory cards remain the property of Investchem Formula 1600. Any cameras or mountings damaged or broken will be replaced by the competitors, at their cost. The onus is on Investchem Formula 1600 to ensure this Judicial Camera is switched on and recording during 2/3 x Race heats and Official Timed Qualifying.

It is the responsibility of Investchem Formula 1600 to ensure the camera is fully charged prior to the required use.

#### **FOOTAGE:**

The footage is the property of Investchem Formula 1600, legally held in trust of each competitor.

It is intended for use only in formal incident inquiries (such as disciplinary hearings etc.) and to enhance the Sponsor's TV production.

Should there be a formal protest / incident at a race meeting the driver's in question footage may be viewed as well as the footage of the closest competitor's car behind or as deemed necessary by Investchem Formula 1600 and / or requested by the Clerk of the Course.

Teams / Entrants / Competitors are reminded that all footage obtained from the SASS championship meetings remains the property of Investchem Formula 1600 and the nominated film production company, and for the avoidance of doubt, without prior permission from Investchem Formula 1600, the footage will not be made available to any competitor or TV producers until after the Thirty minute protest period, after the last heat of the day.

Investchem Formula 1600 allows each member to obtain a copy of their own footage only as a courtesy after the days races are completed. Investchem Formula 1600 would be in breach of its position of trust if it were to give out other competitor's footage for anything other than its intended use. The footage is not available for competitor's personal / informal protests. The championship clerk of the course reserves the right to impose any appropriate penalty on either entrant and / or driver regarding the above and the same will apply should the camera:

- i. Not be switched on.
- ii. Memory card be tampered with, swapped or taken out by any competitor.
- iii. Be deliberately damaged.

In the event that no data is available on request, sanctions may be applied.

**REGULATIONS AND SPECIFICATIONS FOR THE  
2022 FORMULA FORD 1600 KENT NON - CHAMPIONSHIP**

**1. VALIDITY OF THESE REGULATIONS**

These regulations will apply for the calendar year of 2022.

**2. CONTROLLERS**

- 2.1 The Controllers of the Non - Championship are Motorsport South Africa (Pty) Ltd (hereafter referred to as MSA) which has delegated control to the MSA and Investchem Formula 1600.
- 2.2 The Controllers reserve the right to amend, alter or introduce additional rules and regulations and issue interpretation of these regulations as deemed necessary.

**3. ELIGIBILITY OF COMPETITORS**

- 3.1 The Non - Championship is open to all competitors holding a valid Club Competition licences issued by Motorsport South Africa.
- 3.2 The domicile is un-restricted, however, competitors must conform to the rules and regulations of the Investchem Formula 1600 office.

**4. ELIGIBILITY OF VEHICLES**

- 4.1 The Non - Championship is open to all Formula Ford Kent 1600 cars complying with the regulations and specifications tabulated in Article 16 below, but limited to Kent engine cars only which have already been used in Formula Ford racing in South Africa From 1<sup>st</sup> January 1990.
- 4.2 New cars will be permitted only if approved by Single Seater Association appointed technical representative.

**5. CHAMPIONSHIP SERIES AND EVENTS TO COUNT**

- 5.1 The Non - Championship series will consist of 4 x Events for 2022 season.
- 5.2 No Points will be scored towards this Non – Championship
- 5.3 Event 1 : 05 March      Cape Town
- 5.4 Event 2 : 28 May        Port Elizabeth
- 5.5 Event 3: 2 July         Red Star
- 5.6 Event 4 : 15 October    Zwartkops

**6. Starting Grid Positions**

- 6.1 Starting position for race 1 will be determined by Competitors Official Timed Qualifying lap times recorded during official qualifying practice. (SSR 27). The starting positions for race 2 will be Determined by Competitors 2<sup>nd</sup> Fastest Lap time Recorded in Official Timed Qualifying. Competitors that Fail to record Lap times in Official Qualifying will start both Races at the back of Kent 1600 Grid.
- 6.2 In Event of a 3<sup>rd</sup> Race at the Event, then Competitors Starting Grid Order will be in Order that competitors Finished in Race 2 .

**7. RACE DISTANCE**

- 7.1 A minimum of Ten laps per Race, which may be run in two separate races at each event. When a single race of longer duration is run, double the points listed in clause 6 will be scored.

## **8. SPONSORS EXPOSURE AND NUMBERS**

- 8.1 Investchem Formula 1600 will issue each competitor with a competition number. Numbers complying with SSR 4 are to be displayed on the front and both sides of the car in an area that is visible from all angles.
- 8.2 Investchem Formula 1600 will issue competitors with a decal chart and decals, which must be strictly adhered to, failing which a competitor may not be permitted to start an event, or may be excluded from the results of an event (see also GCR's 246 and 247).

## **9. LEGALITY/STRIPPING PROCEDURE**

- 9.1 The pole position car, the race winner and the lap record scorer may be impounded after each race or heat for legality checks.
- 9.2 The engines of at least the six fastest cars may be sealed after Official timed practice, or should Official Timed Qualifying takes place on any day other than on race day. Engines may also be sealed after Race 1 or Race 2 , At the Discretion of Technical Consultant. The Strip will either take place at the circuit in Parc Ferme or will then be arranged for a later Date and Venue with Consent from Clerk of the Course and MSA.
- 9.3 Any Formula Ford at any race, setting a lap record may be impounded and checked for legality. (Refer GCR 252 for Parc Fermé Regulations).

## **10. CONTROL FUEL**

The following procedure will be used to apply control fuel:

- 10.1 An Investchem Formula 1600 appointed technical representative will designate which cars are to run on a control fuel at any time before qualifying or a race.
- 10.2 The competitors concerned will gather at a place designated by Investchem Formula 1600 appointed technical representative no later than half an hour before the event.
- 10.3 Competitors will then be required to drain all the fuel from their race cars. Competitors are required to provide all the necessary equipment to facilitate draining of fuel. The volume of fuel to be drained must exceed fifteen litres. Competitors must provide containers to drain the fuel into. In addition, each competitor must provide a clear see- through plastic container of at least 25 litres in volume to receive control fuel. Control fuel will then be added to each car under supervision and the fuel filler cap and any pipes to or from the fuel tank will then be sealed.
- 10.4 The onus is on the competitors to ensure that they obtain control fuel on time.
- 10.5 Competitors should apply all the necessary safety procedures to ensure that the draining of fuel is undertaken in a safe manner.
- 10.6 A fully charged and operable fire extinguisher of at least 2kg capacity is to be made available by each competitor during fuel draining and refilling at his/her vehicle.

## **11. DECLARATION OF CHAMPION**

- 11.1 This is a Non Championship Series for Kent 1600 Competitors

## **12. AIM OF THE Non- CHAMPIONSHIP**

- 12.1 Club Racing for Competitors to Race.

## **13. STANDING REGULATIONS AND SPECIFICATIONS**

- 13.1 The following as contained in Articles 15 through to 30 are the Standing Regulations and Specifications for Kent- engine Formula Ford vehicles.

## **14. DESCRIPTION**

- 14.1 Four wheel, single seater racing car with open coachwork and complying with these regulations, and table of dimensions Appendix B fitted with a Ford 1600cc GT "Kent" engine.



## **15. SAFETY REQUIREMENTS**

- 15.1 Fire extinguisher – min. 1 kg hand held, within reach of driver when strapped into the seat or 1.75kg remote controlled. Evidence must be available of purchase or service within the previous six months.
- 15.2 Roll over bars and head rests are to comply strictly with the FIA Year Book for the year of manufacturer of the vehicle concerned.
- 15.3 Safety harness – a full 6-point harness is compulsory.
- 15.4 Rain light – a rear facing red warning light of minimum 21 watts with surface area min. 20 sq. cm. Max 40 sq. cm. must be located within 100mm of the centreline of the vehicle and be clearly visible from behind the vehicle.
- 15.5 The warning light must be switched on when visibility conditions are reduced or when instructed by the Clerk of the Course.
- 15.6 The use of Hans Device is Compulsory for all Competitors as Safety Precaution.
- 15.7 Helmets must be FIA – Approved and Incorporate a HANS Device and Fixtures
- 15.8 Fire Resistant Clothing ( Minimum 2 x Layer Race Suit + Gloves + Racing Boots + Underwear + Socks + Balaclava)

## **16. CHASSIS**

- 16.1 The chassis must be of tubular steel construction with no stress bearing panels except bulkheads and undertray. Undertray curvature must not exceed 25mm. The undertray / floor extends from the bulkhead forward of the pedals to the bulkhead between the fuel tank and the engine. Mono-coque chassis construction is prohibited. Stress bearing panels are defined as sheet metal affixed to the frame by welding or bonding or by rivets, bolts or screws which have centres closer than 150mm. Bodywork must not be used as stress bearing panels. The use of stabilised materials, composite materials using carbon and/or Kevlar reinforcement is prohibited.
- 16.2 Cars built after 1.1.1990  
The internal cross section of the cockpit from the driver's feet to behind his seat, shall nowhere be less than 700cm<sup>2</sup> and minimum width must be 25cm over the whole length of the cockpit. The only intrusion permitted into the cross sectional area being the steering column.  
Cars built after 1. 1.1995  
The chassis must include an impact-absorbing structure fitted ahead of the front bulkhead of the tubular steel frame. This structure must be independent of the bodywork and must solidly fixed to the extremities of the bulkhead ( i.e. with bolts requiring tools for removal).  
It must constitute a box of 30cm minimum length, 15cm height in any vertical section and 400 cm<sup>2</sup> minimum total cross section. It must be metallic using honeycomb sandwich construction with a panel thickness of 15mm minimum. It is mandatory that this safety feature is fitted to Cars manufactured after 1<sup>st</sup> January 1990.

## **17. BODYWORK**

- See tables of single seater dimensions. (Appendix "B"). Bodywork is not required behind the vertical plane taken through the front of the topmost portion of the roll over structure. If bodywork is used it must conform to the following regulations:  
All bodywork must comply with either these regulations applicable for the year of manufacture of the car in their entirety.
- 17.1 Any device designed to augment aerodynamically the downthrust on the vehicle is prohibited, as are aerofoil, nose fins or spoilers of any type.
  - 17.2 For cars built after 1.1.1990  
The engine cover must not extend rearwards past the rearmost point of the gearbox housing (no gearbox extensions permitted). The shape of the cover must not include any reflex curves and no flat surfaces are permitted within 15° of the horizontal.
  - 17.3 For cars built after 1.1.1990  
The lower rear bodywork (located below the wheel centre line) is only permitted alongside and beneath the engine and can only extend from behind the cockpit to a line drawn through the rear wheel axis. The incorporation of suspension or other fairings in this bodywork or separately is prohibited.
  - 17.4 It is not permitted to construct any suspension member in the form of an aerofoil or to incorporate a spoiler in the construction of any suspension member.
  - 17.5 All cars must have at least two mirrors mounted so that the driver has visibility on both sides of

- the car.
- 17.6 For cars built after 1.1.1995 cockpit opening :The opening giving access to the cockpit must allow a designated horizontal template to be inserted vertically into the cockpit ( not considering the steering wheel) down to 25mm lower than the lowest point of the cockpit opening. This template is defined by dimensions J,K,L in Appendix B
- 17.7 See also Lateral Protection Structures.
- 17.8 All competitors must run with complete (all) bodywork during all practice sessions which shall normally commence on the Friday of the race meeting, this includes both race heats. Unless the bodywork is damaged in such a way that it cannot be fitted and fastened to the vehicle to prevent it from coming loose and endangering other competitors.
- 17.9 Cars manufactured after 1.1.1990 must retain the original type sidepods as per manufacture and may fit larger radiators and sidepods ,but not smaller as the sidepods are part of the crash safety structure.
- 17.10 These cars were designed with safety structures ,sidepods are part of the safety structure.1998 onwards.

## **18. ENGINE**

### **18.1 General**

- a) Engines will be mounted upright, and aligned fore and aft in the chassis.
- b) The addition of any material be it metal, plastic or composite, etc. by means be it welding, bonding, encapsulation or encasement to any component, is prohibited. However, specific repair of the mounting points of the cylinder block to the transmission are allowed, whilst other casting repairs may be allowed with prior written approval of the Investchem Formula 1600 appointed technical representative.
- c) Balancing of reciprocating and rotating parts is permitted only by removal of metal from locations so provided by the manufacturer.
- d) Pump, fan and generator drive pulleys and their retention bolts are free.
- e) Mechanical tachometer drives may be fitted.
- f) The use of non-standard replacement fasteners, nuts, bolts, screws, studs and washers which are not connected with, or which do not support, any moving parts of the engine or its compulsorily retained accessories, is permitted. Freedom granted to any fastener does not allow for freedom to move items relative to each other. For components that are granted the freedom for the fitment of a key or dowel, then material may be removed to allow the fitting of the key or bowel. Only one hole or keyway per component is allowed.
- g) The use of thread locking compounds is permitted.
- h) Gaskets are free except as follows:
  - i) the inlet manifold gasket and carburettor base gasket must be of standard Ford manufacture for the Ford Kent 1600cm<sup>3</sup> GT uprated engine. The inlet manifold gasket compressed thickness may not exceed 1mm. The carburettor base gasket thickness may not exceed 5,7mm ( $\pm 0,35$ mm).  
Note: Ford V6 bridge plate base gaskets, flexible carburettor mountings and rubber base gaskets or any other gaskets not specifically allowed in these regulations are prohibited.
  - ii) the cylinder head gasket may be of standard Ford manufacture or any equivalent gasket having a minimum compressed thickness of 0,85mm providing no performance advantage is gained.
- i) Any process of cleaning may be used on any component providing the surface finish, which must remain standard, is not affected.
- j) Forced induction is prohibited. Ram Air generated by the forward motion of the car is not considered as forced induction.
- k) The exterior surface only (of the complete engine assembly) of ferrous parts and the exterior surface of the aluminium cam cover may be protected by paint or similar means. No internal component or surface may be coated by any protective finish. Other Ford produced aluminium components may be protected only on their external surfaces by transparent clear varnish, or similar.

### **18.2 Permitted engine**

The only permitted engine is the FORD 1600 GT "Kent" with a Maximum nominal bore 81.007mm

and a Maximum stroke 77.62mm +/- 0.10mm. Production Tolerances are permitted providing the Total Swept Volume does not exceed 1600cc

### 18.3 Induction

- a) The air cleaner may be removed or replaced and a trumpet fitted.
- b) Carburettor Type: Weber 32/36 DGV and DGAV (from 1600 GT "Kent" or 2000 SAHC NE engine).
 

Number on engine	1
Number of Main Venturi	2
Maximum dia. of Main Venturi	26.0/27.0mm
Maximum dia. of carb outlet to inlet manifold	32.0/36.0mm
- c) It is permitted to change jets, open both throttles together, remove cold start devices and diffuser bar, fit internal and external anti-surge pipes, remove seals on emission control carburettors. No other modifications are permitted, choke must remain standard and no polishing or reprofiling is permitted. Any means of reducing intake air temperature is prohibited. Any form of water injection is prohibited.
- d) Inlet manifold: standard Ford production inlet manifold for 1600 GT "Kent" engine. The carburettor seat face may be machined to horizontal in the fore and aft plane. The water passage must remain intact but may be blanked off or plugged. The manifold may be machined externally to clear the throttle mechanism.
- e) Carburettor to inlet manifold gasket, including Spacer + 2 x Gaskets
 

Thickness	5.70mm ± 0.35mm
Inlet manifold to cylinder head	Thickness 1.00mm (max)

 3.5, 4.0, 4.5, full width cross tube auxiliary Venturi's are the only ones permitted, they may not be modified in any way whatsoever.

### 18.4 Exhaust System

- a) The exhaust system and manifold are free, within Vehicle Regulations.
- b) The exhaust system must be fitted with a UK Spec Investchem Formula 1600 Silencer and comply with the noise test level as per GCR 245.
- c) Exhaust SASSA Silencer Dimensions 390 mm Long x 140mm OD and 52.0 mm ID Perforated tube

### Cylinder Head

- d) Non-standard rocker covers are permitted providing they in no way improve the performance of the engine. Water passages are not permitted in rocker covers.
- e) Standard valve spring retainers must be used, only single valve springs are permitted. Shims are permitted, otherwise valve springs are free.
- f) Push-rods, rockers, tappets, pedestals and shafts must remain standard except that recontouring of the valve stem contact pad on the rocker arm is permitted providing the maximum specified lift at the spring cap is not exceeded. Rocker shaft springs are free.
- g) Maximum permitted lift at the spring cap with zero tappet clearance:
 

Inlet	10,00mm
Exhaust	10,10mm

 Maximum permitted lift at the top of the push rod:
 

Inlet	6,50mm
Exhaust	6,536mm
- h) Valves must remain standard, no reprofiling or polishing is permitted. The original 45° seat angle must be maintained.
 

Distance apart at centres diameter,	39,12 ± 0,5mm	Maximum face
	inlet 39,62mm	
	exhaust 34,00mm	
Overall length	inlet 110,92 ± 0,5mm	
Overall length are optional	exhaust 110,61 ± 0,5mm	Valve stem seals
- i) It is permissible to reshape inlet and exhaust ports by removal of metal only. Addition of material in any form is prohibited.
- j) It is permitted, as a means of repair, to replace damaged valve guides and valve seats by replacement valve guides and valve seat inserts, all standard dimensions.

### 18.5 Cylinder Block

- a) Bores may be repaired by the fitment of cast iron liners up to a maximum diameter of 81,007mm.
- b) Localised machining of the block is permitted to allow fitment of a dry sump system.

- c) Crankcase breather may be removed or altered.
- d) The block may be machined to achieve correct deck height.
- e) The crankshaft horizontal axis (in the block looking from the front of the cylinder block) may not be offset in any way from the original location.

#### 18.6 Compression Ratio

The maximum compression ratio will be controlled as follows:

- a) Minimum combustion volume in piston, 41.00cc (with piston at TDC in cylinder and no account taken of volume down from the crown to the top piston ring). This measurement is achieved using Regular Paraffin only as the liquid. ( No Tolerance allowed)
- b) Standard Ford cylinder head gasket or equivalent only are permitted.  
The Only Cylinder Head gasket with Part No: 781M 6051 AA or 931 M 6051 AA are permitted.  
minimum compressed thickness 0,85mm  
minimum diameter of cylinder aperture 82,50mm
- c) Pistons must not protrude above the cylinder block face at TDC. The cylinder block may be machined.
- d) Maximum permitted protrusion of the valves into the combustion chamber: 1.20mm.

#### 18.7 Camshaft

- a) The only permitted camshaft is that supplied by the Investchem Formula 1600 appointed technical representative. The 270 degree profile Camshaft that is Profiled and Heat Treated by the Investchem Formula 1600 One and Only Approved Supplier may be used.
- b) Specifications and serial numbers for the camshafts will be kept by the Investchem Formula 1600 appointed technical representative for the purpose of scrutineering checks.

#### 18.8 Pistons

- a) Pistons must be standard production pistons for the Ford 1600cc Kent engine, unmodified in any way except for balancing and as detailed.
- b) All three piston rings must be fitted, and must be standard production or similar replacements, ie. The compression rings must be one piece, with conventional plain gaps, chromium plating of the top ring is optional, the oil control rings must be either single piece twin land type of apex three piece (two rails and an expander). Molybdenum faced top compression rings are permitted.
- c) Localised machining of the bowl including valve relief and gudgeon pin and bosses of the piston to achieve volumetric and weight balance is permitted. Minimum weight complete with piston rings and gudgeon pin is 516gm.
- d) Teflon buttons as gudgeon pin retainers in place of circlips are permitted.
- e) Machining of the underside of three of the piston crowns to achieve mass balance is permitted.
- f)

#### 18.9 Connecting Rods

- a) Connecting rods must be standard Ford components for the 1600 Kent engine. Machining is permitted to remove metal from the balancing boss on the big end cap and around the small end to achieve balancing only. Polishing is prohibited. Minimum weight ( including bolts + small ends bushes + 2 x Big End Bearing Shells) is 640 grams.
- b) Standard 1600 Kent Big end bolts or Ford 3000 V6 Big end bolts or ARP big end bolts are permitted.

#### 19.11 Crankshaft

- a) A Standard crankshaft or a Steel equivalent Crankshaft specifically manufactured for the Ford 1600 Kent engine may be used.  
Spot Machining to achieve balance is permitted.  
Tuftriding , Shot peening and shot blasting are permitted. Polishing is prohibited.  
Standard Cast Crankshaft Minimum Weight = 11.10 Kg  
Steel Crankshaft Minimum weight = 11.50 Kg
- b) Crankshaft pulley is free as a tooth belt drive.
- c) It is not permitted to alter the number of bearings or fit bearings of less than standard production width.
- d) Standard, oversize and undersize bearings are permitted.
- e) The rear main journal may be fillet rolled in the radius.

#### 19.12 Flywheel and Clutch

- a) The flywheel and clutch assembly must be standard components. To achieve minimum weight and balance, material may be removed. For rectification, the clutch mating face may

be resurfaced. It is permitted to use a similar pattern replacement clutch (i.e. conventional single diaphragm spring) driven plate with shock absorber springs. Organic friction material only is permitted. Racing clutches are prohibited.

- b) Flywheel bolts are free and locating dowels are permitted.
- c) It is permitted to secure the starter ring to the flywheel.
- d) Flywheel minimum permitted weight: 6.250 kg ( Flywheel ONLY including Ring Gear).

#### **19.13 Lubrication Systems**

- a) The lubrication systems, external to the engine, are free. Existing standard production oil-ways, linings or oil grooves may be enlarged or reduced, but no additional ones are permitted. Friction surfaces must remain unchanged. Dry sump is permitted, oil coolers are free. Oil Pipes are Free.

#### **19.14 Cooling System**

- a) A liquid cooling system is mandatory but radiator/s and water pump are free.
- b) The radiator/s, if housed in or incorporating a cool air scoop or deflector, must comply with bodywork regulations.

#### **19.15 Fuel Pump**

- a) Only standard mechanical fuel pump for engine is permitted.
- b) Fuel pipes are free. Fuel cooling radiators are permitted, within safety regulations, but must be mounted within the main chassis frame.

#### **19.16 Distributor**

- a) Distributors are free providing they retain the original drive and location.
- b) The distributor is defined as the component which triggers the LT current and distributes the HT ignition current. The ignition timing may only be varied by vacuum and/or mechanical means. It is prohibited to use any other method or component to trigger, distribute or time the ignition.
- c) It is permitted to mount a simple indicating pointer to the engine to facilitate the timing of the distributor with respect to the crankshaft/flywheel.
- d) Electronic ignition is permitted providing this is by means only to replace the current points and condenser in the distributor. Electronic programmable Distributors are not Permitted.
- e) Points and condenser may be retained

### **19. SUSPENSION**

- 19.1 The following parts must be of alloy steel or other ferrous material: wishbones, rockers, push and/or pull rods. All other stress components must be metallic with no composite materials allowed. It is permitted to incorporate suspension mounting points on the engine and transmission assembly.
- 19.2 Active suspensions are prohibited, as is any system which allows control of the flexibility of the suspension springs, shock absorption and trim height when the car is moving.
- 19.3 Anti-roll bars from front and/or rear suspension may be capable of manual adjustment by the driver when seated in the car.
- 19.4 Simple ovalised tubes which have the same section top and bottom are not considered to be an aerofoil.

### **20. BRAKES**

Only brake discs made predominantly from ferrous material are permitted. Callipers must be of ferrous material with a maximum of two working cylinders per calliper. Brake pad materials, including carbon metallic, are free.

### **21. SHOCK ABSORBERS**

Light Alloy or Steel casings are Permitted . Each Dampers may only have a maximum of two way adjustable ie: ( 1 x Bump + 1 x Rebound Adjustment). Separate reservoirs/canisters for fluid/gas are prohibited. Otherwise free . Any form of active damping is prohibited. Any method of altering the damper performance by the driver whilst seated in the car is prohibited. The shock absorber casing is defined as the item which contains the piston, fluid/gas ,and the moving parts which control the damping action.

The use of Blow Off Valves , Inertia valves , External Electronic Inputs , Storage of Energy or any any Hydraulic connection between dampers are not Permitted

## 22. STEERING

The steering must consist of a mechanical link between the driver and the wheels, rear wheel steering prohibited, otherwise free.

## 23. WHEELS AND TYRES

- a) 13 Inch diameter wheels with a maximum rim width of 6 inches and minimum mass of 5.0 kg (Including 4 x Retaining Wheel Nuts) are the only wheels permitted. They must be of standard manufacture but the off-set may be altered. Madin Alloy three piece rims + OZ Racing rims are allowed providing they conform with the required mass and width. Competitors may also use UK Spec Steel Rims 5.5 inch width as an Option.
- b) Tyres must be used as directed by the Single Seater Association appointed technical representative, from the official tyre supplier.
- c) The Investchem Formula 1600 appointed technical representative will determine which races will be new tyre races. The onus is on the competitor to ascertain which races are new tyre races.
- d) The Investchem Formula 1600 appointed technical representative reserves the right to introduce a new tyre and size of rim and tyre.

### Tyre Restriction

- a) Competitors will only use the AVON ACB 10 tyres purchased from Investchem Formula 1600, unless otherwise notified in writing. Purchased tyres may be selected at Random from the stock.
- b) Competitors shall be limited to the use of two sets of tyres, new or used tyres (i.e. 4 front + 4 rear) for the entire 2022 season and Registered with the Investchem Formula 1600 TC. Competitors may use old or new tyres as a competitors tyre allocation for Official Timed Practices ( Friday ) , and Official Timed Qualifying and Races 1 + 2 for the event of the 2022 Non- Championship ( Recorded Tyre Serial Numbers with TC )
- c) The Non - championship tyres registration of the allocated tyres for Competitors will officially begin at the 1<sup>st</sup> Official timed Practice session for the 1<sup>st</sup> Event of the Non – championship 2022 season. ( Friday)
- d) The serial numbers of all tyres to be used, as specified above, will be recorded. The onus is on the competitor to ensure that these serial numbers are recorded timeously and correctly. The race scrutineers and/or Investchem Formula 1600 representative(s), TC will check the serial numbers at random at any time. The use of tyres with incorrect serial numbers, during any official practice or race, may result in exclusion from the race meeting concerned as well as the imposition of further penalties.

e) Tyre Size: Front : 6.0 x 21 x 13 inch    Rear : 7.0 x 22 x 13 inch

## 24. TRANSMISSION

- a) The gearbox must contain not more than four forward gears and include an operable reverse gear, capable of being engaged by the driver whilst normally seated. The gear ratios are free.
- b) Rear wheel drive only is permitted.
- c) Final drive ratio is free.
- d) Torque biasing, limited slip and lock differentials are prohibited. Non ferrous differential components are permitted provided that at any temperature they do not provide any form of torque biasing etc. The only differential permitted is the "SALISBURY TYPE FREE DIFFERENTIAL". The car stationary with one rear wheel lifted off the ground, must allow the lifted wheel to be rotated continuously by hand relative to each other in both directions."  
Note: This wording does not exclude other makes of differentials or "Diff carriers" as long as they do not produce limited slip or torque biasing.
- e) Gear change must be manual in operation. The gear change must use the conventional H-pattern gear change gate. Any gear change mechanism that allows sequential selection of gears is not permitted.
- f) The only position for the main gear cluster will be wholly behind the rear axle output shaft centre line, and in line with the crankshaft centre line. Transverse, vertical, or other non in-

line configurations will not be allowed.

## 25. FUEL SYSTEMS

- a) Tanks outside the chassis frame must comply with FIA Spec FT3.
- b) Inboard tanks, covered externally with a fireproof coating, are acceptable for events less than 70km.
- c) Only PUMP FUEL with a Maximum of 95 Octane Rating is permitted, Unleaded or LRP. Fuels specified in the 2022 MSA Handbook (GCR 240) shall be used. The addition of any additive which improves the performance of the fuel is prohibited.
- d) Maximum capacity 40 litres unless carried in FIA Spec FT3 tank.
- e) The Investchem Formula 1600 appointed technical representative has the right to introduce a control fuel at any time at their discretion.
- f) Fuel from breather pipes must be routed in such a manner that irrespective of the angle of the vehicle no fuel spillage will occur.
- g)

## 26. STARTING

- a) Compulsory electric starter with electrical source of energy carried on board the car, and able to be controlled by the driver when normally in his seat.
- b) A supplementary external source of energy temporarily connected to the car may be used to start the engine whilst in the pit area or on the dummy grid.

## 27. ELECTRICAL SYSTEM

- 27.1 To be equipped with an externally operated circuit breaker having positive ON-OFF positions clearly marked. An internal ignition switch must be operable by the driver when normally seated irrespective of whether a safety harness is worn or not.
- 27.2 External circuit breakers: the circuit breaker, when operated, must isolate all electrical circuits with the exception of those that operate fire extinguishers and other specifically specified components. On the cars, it should be situated on the lower main hoop of the rollbar. The location to be identified by a "red spark on a white-edged blue triangle", and the "ON" and "OFF" positions clearly marked, Note: When the cut-out is operated there must be no power source capable of keeping the engine running.

## 28. MASS

- a) **Cars manufactured after 01/01/1990**  
(i.e. cars with a pushrod type suspension & LD200 gearbox)  
Minimum mass, car plus driver, at any time during a competition = 520kg

## 29. ENGINE SEALING

All engines should have provision for scrutineers wire seals. 1,5mm dia. holes pre-drilled in readily accessible locations on installed engines, must be available. Failure to comply renders the entrant liable to a fine or exclusion.

- a) Sump – two holes through the cylinder block/sump joint flange, one either side of the engine.
- b) Timing cover – at least two retaining screw heads must be cross drilled.
- c) Rocker cover – at least two retaining screw heads must be cross drilled.
- d) Inlet manifold – at least two retaining bolt heads to the cylinder head must be cross drilled.
- e) Carburettor – at least two retaining nuts to the cylinder head must be cross drilled.
- f) Bellhousing – at least two retaining bolts to the engine must be cross drilled to enable clutch and flywheel to be adequately sealed, OR competitors must be prepared to remove either engine or transmission to enable sealing of clutch and flywheel in which case at least two clutch cover retaining bolts must be cross drilled. Failure to comply renders the engine ineligible.

### 30. MISCELLANEOUS

- a) Use of titanium, high strength composites and similar materials is prohibited.
- b) Electronic Dashboards and Data logging equipment are allowed subject to the Device having NO influence whatsoever to the Behaviour of the car or engine during competition. All instrumentation obtained and recorded from any data loggers or Storage equipment shall be made freely available to the Investchem Formula 1600 TC . Any Data Logger is subject to the approval of Investchem Formula 1600
- c) Competitors are reminded that only modifications or additions specifically covered by these regulations are permitted. Engine components not covered by these regulations must remain completely standard and unmodified. In case of dispute on engines, reference will be made to Ford Motor Company Limited drawings.
- d) Vehicles defined in these regulations are required to comply with the requirements of the 2022 MSA Handbook.
- e) Ground clearance is defined as the clearance between the ground and the lowest part of the bodywork, and or of the suspended part of the car in normal race trim with driver on board the car.

### SPECIFIC REGULATIONS FOR CARS MANUFACTURED AFTER 01/01/1990

#### 1. Description

Single seater racing cars complying with current Formula Ford 1600 Kent regulations.

#### 2. Chassis

The chassis specification must remain fundamentally unaltered from original manufacture. Wheelbase, track and pick-up points must remain to manufacturer's specifications.

#### 3. Permitted Modifications

3.1 To current FF-1600 Kent regulations.

3.2 Any modifications of which the primary purpose is safety or driver comfort.

3.3 Bodywork is free within FF-1600 dimensions but must remain the same as that fitted to the vehicle in its year of manufacture.( As per car was manufactured) This regulation applies to sidepods. Specifically for cars manufactured after 01 January 1998 must retain original sidepods.

3.4 Coil springs, shock absorbers, anti-roll bars and steering racks are free providing they fit the same original locations and comply with regulations.

3.5 Wheel off-sets may be varied to alter track dimensions.

3.6 Make and type of drive shaft is free.

### APPENDIX "B" (KENT)

Table of single seater dimensions



**FORMULA FORD**

**APPENDIX "B" (KENT)**  
Table of single seater dimensions

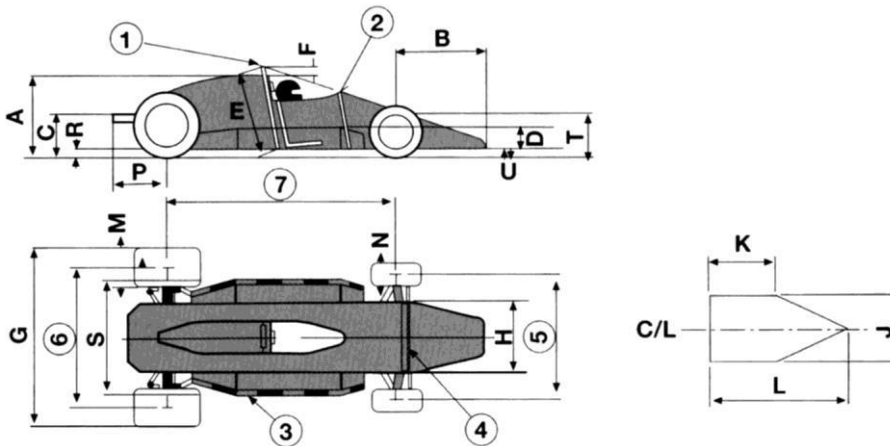

- |  |   |
|--|---|
| <ul style="list-style-type: none"> <li>1. Safety roll over bar</li> <li>3. Lateral Protection structure</li> <li>5. Front track</li> <li>7. Wheelbase</li> </ul> | <ul style="list-style-type: none"> <li>2. Substantial support structure</li> <li>4. Substantial structure</li> <li>6. Rear track</li> </ul> |
|--|---|

**NOTES:**

Maximum height is measured with the driver aboard.  
Maximum height excludes safety roll-over bar on which there is no maximum height.

**SINGLE SEATER DIMENSIONS (KENT) – REFER TO DRAWING**

A) Maximum body height measured from ground	900
B) Maximum front overhang from front wheel axis	1000
C) Exhaust height measured from the ground	600 max.
D) Minimum height of Lateral Protection Structure	150
E) Minimum safety roll-over bar length in line with drivers spine	920
F) Minimum allowed helmet clearance	50
G) Maximum width	1850
H) Maximum body width behind front wheels	950
J) Minimum cockpit opening	450
K) Minimum cockpit parallel opening length	300
L) Minimum cockpit overall opening length	600
M) Maximum rear wheel width	6.0 inches
N) Maximum front wheel width	6.0 inches
P) Maximum exhaust length from rear wheel axle	600
R) Minimum ground clearance	40
S) Maximum width including lateral protection structure	1300
T) Maximum height of any part wider than 110cm ahead of the front wheels is not to exceed the front rim height	
Minimum wheel base	200
Minimum track	120
Wheel diameter	13 inch

Note: All dimensions in mm unless otherwise stated